



no buildings | no roads | no power lines
just great reliability.

World Headquarters

39 Grand Canyon Lane
San Ramon,
CA 94583 USA

President

Frank Martens

Phone

925.901.0103

Fax

925.901.0403

Peninsula Engineering

Solutions, inc. may
change specifications as
necessary to meet
industry requirements.

Website www.peninsulaengineering.com

Email fmartens@peninsulaengineering.com

RF-1500E Repeater

Microwave Repeater Systems

Applications

- Low-cost, highly reliable 1.5 GHz microwave through repeater for extending range of or clearing obstructed microwave radio paths.
- Excellent performance with analog, digital, or video microwave radios; channel capacity to 300 FDM, 8 Mb/s PCM, and point to multipoint TDM/TDMA.
- Compatible with any manufacturer's 1.5 GHz radio terminal.
- Solar power compatible -- economical in thin routes and remote locations.

Features

- Power consumption only 2.2 amperes at 12 Vdc for duplex operation.
- Solar powered, ac powered, or powered by primary cells.
- Compact and lightweight -- ideally suited for remote sites that do not have access roads or commercial power.
- Environmentally protected aluminum, weathertight, lockable cabinet. No extra environmental shelter required in most installations. Suitable for use at unimproved sites anywhere in the world -- Alaska to Saudi Arabia.
- Internally protected duplex, frequency diversity, and three-way or "Y junction" configurations available.
- Only one active element per channel, the internally redundant linear amplifier.
- AGC/ALC provided to correct input fades and reduce overload.
- Maximum gain can be field-adjusted for easy fine-tuning.
- In the case of single duplex configuration, amplifiers can be replaced without disrupting service.
- RMAS-100 Alarm system (optional) can remotely monitor repeater.
- Equipped with directional couplers for in-service RF output power measurements.
- No frequency conversion -- received signal is filtered, amplified, and re-radiated.
- Very reliable, greater than 85,000 hours MTBF for duplex.
- Available as a self-contained RF repeater for use with customer-furnished antenna and power equipment or as a complete package including repeater, antenna, solar electric panels, battery charger, and batteries.

Table of Contents

APPLICATIONS	01
FEATURES	01
TECHNICAL SUMMARY	02
1. GENERAL	06
2. FUNCTIONAL DESCRIPTION	06
Basic Repeater	06
Amplifiers	06
Directional Couplers	11
AGC/ALC Adjustment	11
Power Supply	11
3. ALARMS	11
4. LICENSING	12
5. ORDERING	12
6. INSTALLATION	13
General	13
Power Wiring	19
DC Power	19
7. TESTS	19
General	19
Test Equipment	19
Application of Power	19
Antenna Isolation Measurement	21
Antenna Orientation, AGC/ALC set and Output Measurement	21
8. MAINTENANCE	21
Routine Maintenance	21
Administration Requirements	22
Trouble Location	22
Amplifier Replacement, Out of Service	22
Amplifier Replacement, In Service	22
Return Procedure	23
APPENDIX A	25
Antenna System	25

1. GENERAL

- This Section provides information for the Peninsula Engineering RF-1500E, RF Repeater Assembly; hereinafter referred to as the RF-1500E. The RF-1500E may be used with any manufacturer's 1.5-GHz radio operating in the 1.427-1.535 GHz frequency range to provide an intermediate repeater.
- The RF-1500E assembly is an RF through repeater designed for remote locations. No tuning is required, and the use of highly reliable components and minimum active circuitry eliminates most subsequent maintenance. The repeater assembly consists of an equipment mounting panel, contained in a aluminum, weatherproof cabinet. If desired, the equipment mounting panel only may be mounted in a standard 19-inch (483-mm) rack, or the complete assembly may be wall-mounted. In most applications however, the complete assembly is pole- or tower-mounted. Front views of the repeater are shown in Figures 1.1 and 1.2.
- In addition to the RF-1500E repeater assembly, Peninsula Engineering offers accessory equipment consisting of antennas and mounting hardware, coaxial cable, batteries and hardware, and an ac power supply with an integral standby battery. The recommended antennas are parabolic grid, solid or high performance types chosen per application.

2. FUNCTIONAL DESCRIPTION

Basic Repeater

- The RF-1500E duplex repeater uses internally redundant amplifiers for transmission in each of two directions. Each amplifier is powered by two separate battery supplies for added reliability. Bandpass filters and circulators, which form a duplexer network, direct the received signals to the amplifiers and combine the amplifier outputs with the received signals to a common antenna port for transmission in each direction (see Figures 2.1~2.3).
- The received signal from "A" antenna, identified as frequency "f1," connected through N(male) to N(male) jumper supplied, enters the repeater panel via the panel mounted type N (f) connector and is then fed to a branching circulator. From the

circulator, the f1 signal is passed to an isolator and then to the f1 receive bandpass filter. The bandpass filter passes the f1 signal to a second isolator and (optional) f1 receive pad and then to amplifier A1. The (optional) delay equalizer assembly just before the input port of the amplifier will route the signal via a circulator to delay equalizer which will correct the group delay within the specification. The signal then is routed back to the main route via the circulator into the amplifier. The amplified f1 signal passes to the (optional) f1 transmit pad. From the transmit pad, the f1 signal then passes the isolator and the f1 transmit bandpass filter to the branching circulator and then to the panel mounted type N(female) connector for connection to "B" antenna through the second N(male) to N(male) jumper.

- In the other direction, the received signal from "B" antenna, identified as frequency "f2," enters the repeater panel via the coax jumper to the panel mounted type N(female) connector and is then fed to a branching circulator. From the circulator, the f2 signal is passed to an isolator and then to the f2 receive bandpass filter. The bandpass filter passes the f2 signal to a second isolator and (optional) f2 receive pad and then to amplifier A2. The (optional) delay equalizer assembly just before the input port of the amplifier will route the signal via a circulator to delay equalizer which will correct the group delay within the specification. The signal then is routed back to the main route via the circulator into the amplifier. The amplified f2 signal passes to the (optional) f2 transmit pad. From the transmit pad the f2 signal then passes through an isolator and the f2 transmit bandpass filter to the branching circulator and then to the panel mounted type N(female) connector for connection to antenna "A" through the coax jumper supplied.

- Receive pads reduce the repeater receive signals to approximate the recommended input level. The transmit pads reduce the output signal levels of the repeater to prevent overloading of the terminal receiver in a short path. Pads are mounted on input and output of amplifiers. Table 2.1 shows the nominal input and output power level for single channel Level 1 duplex configuration. Detail information for other configurations is in Technical Summary at the beginning of this manual.

Amplifiers

- In digital radio applications, in order to maintain linearity

FIGURE 1.1
MECHANICAL LAYOUT, DUPLEX

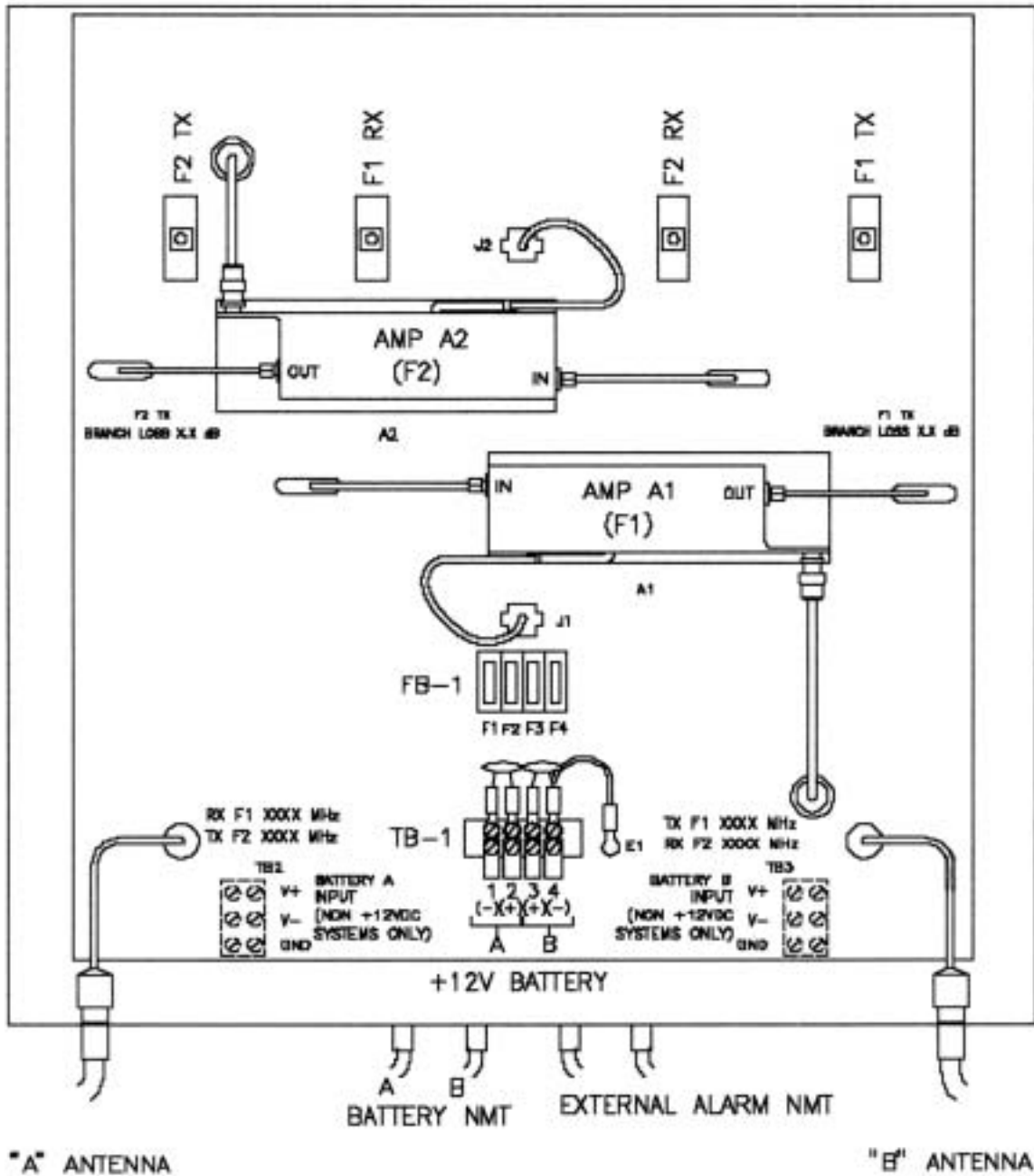

FIGURE 1.2

MECHANICAL LAYOUT, DUPLEX
FREQUENCY DIVERSITY

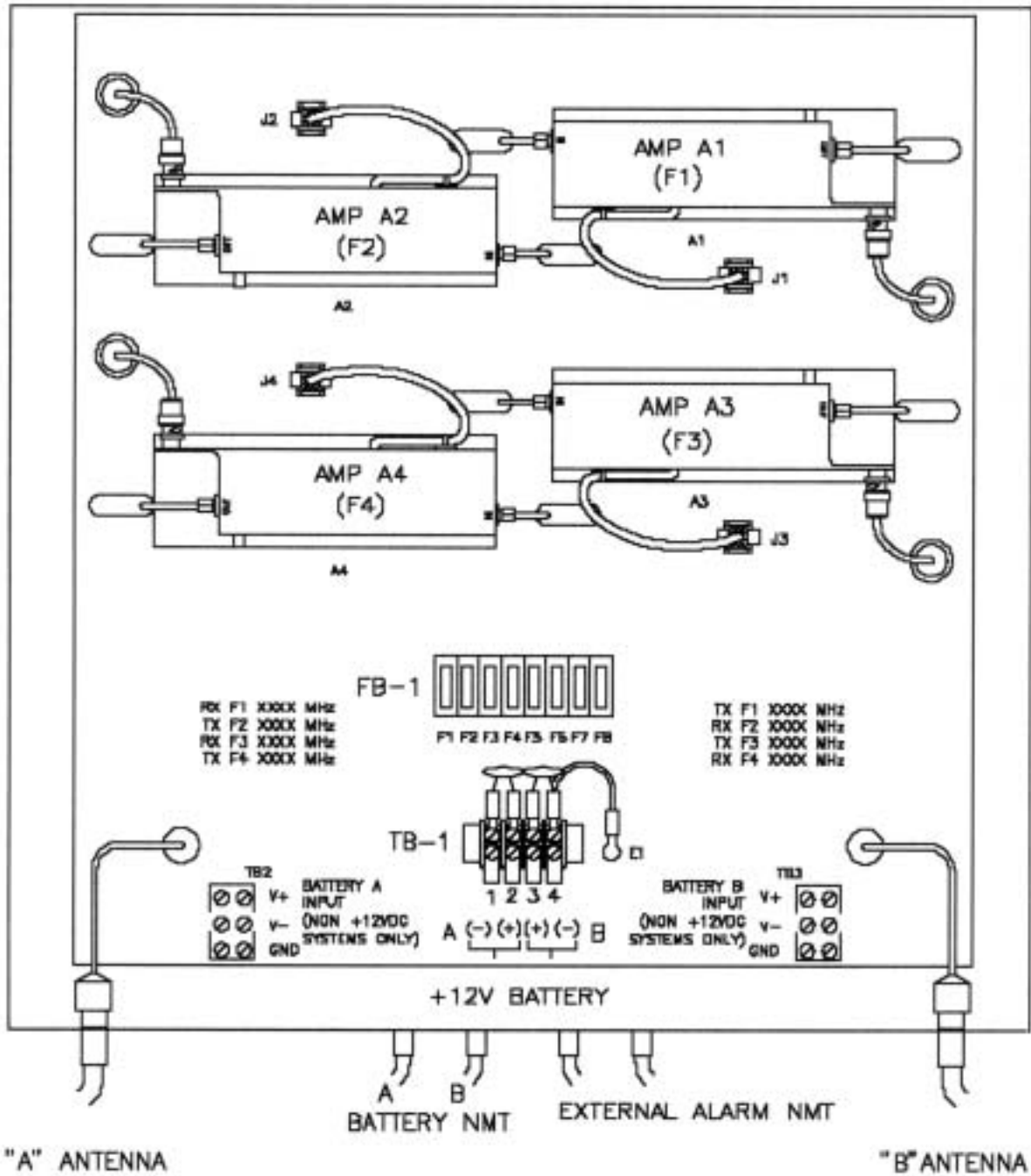

FIGURE 2.1
RF REPEATER, DUPLEX

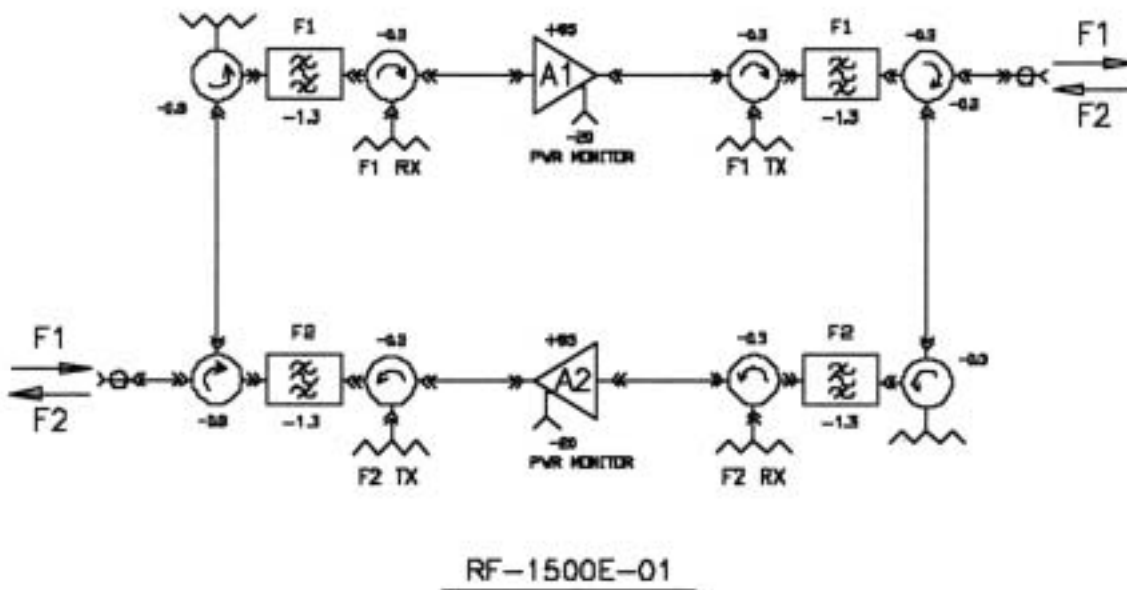

FIGURE 2.2
RF REPEATER, ONE WAY

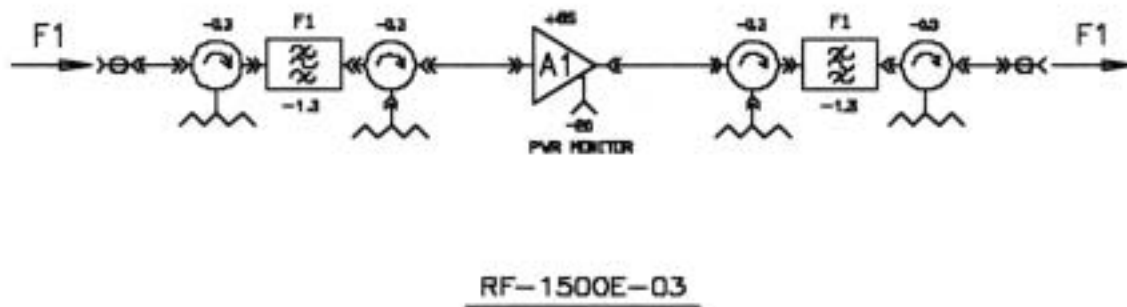
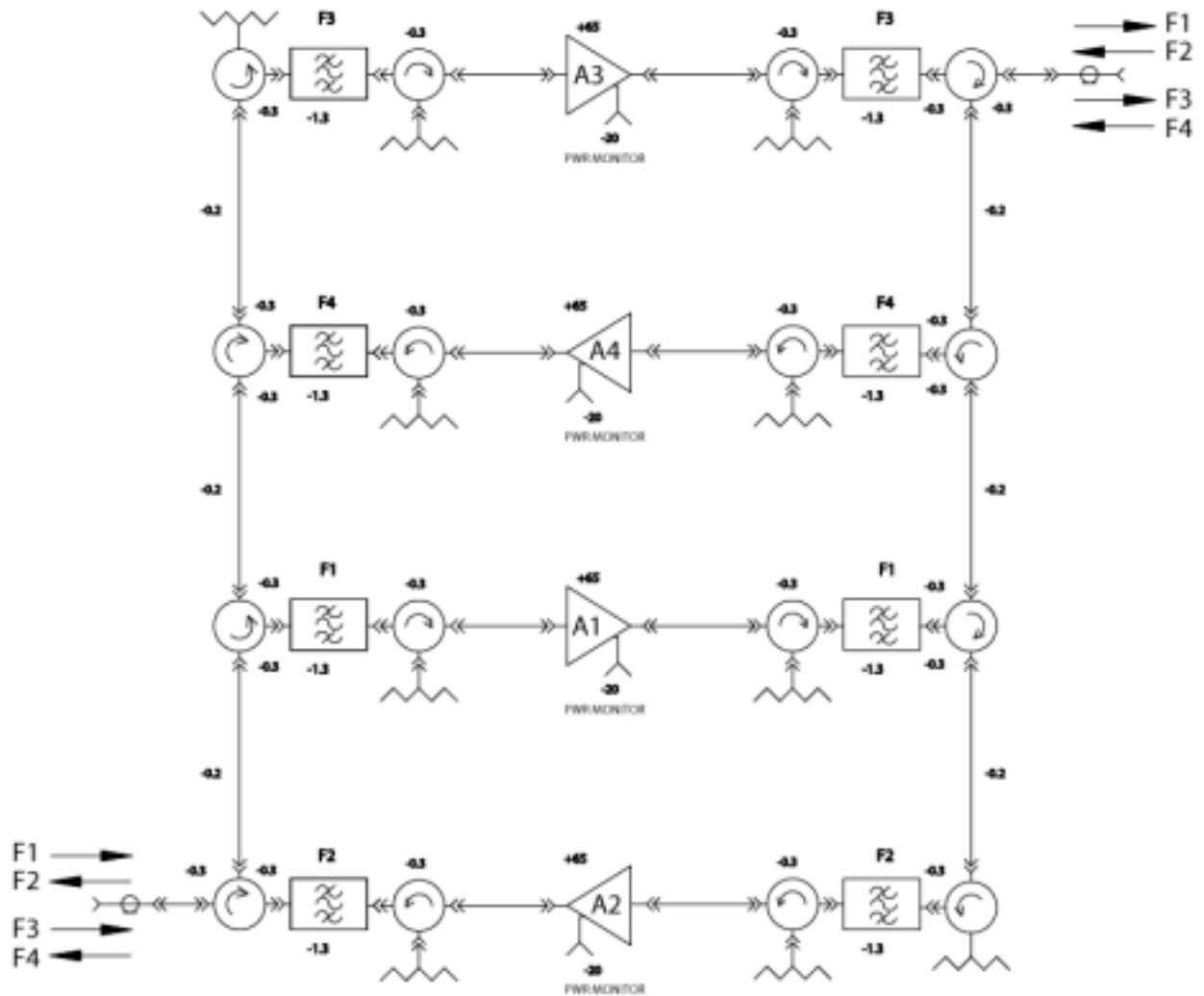

FIGURE 2.3

DUPLEX, FREQUENCY DIVERSITY



RF-1500E-02

RF-1500E Repeater

over the entire signaling envelope, the amplifiers operate at a reduced average power level to meet the output power level requirement as shown in Table 2.1. Each amplifier is mounted on the front of the panel to allow easy AGC/ALC adjustment and amplifier replacement in the field. Necessary information for ordering spare or replacement amplifiers is provided in Part 5, Ordering.

Directional Couplers

- Directional couplers, built into the amplifiers, provide signal monitor points (Figure 2.4). These allow in-service measurement of transmit output power. The monitor points are calibrated to indicate actual RF out-put power at the antenna connector. When measuring transmit power, the power meter reading obtained, plus the loss (in dB) marked at the amplifier monitor point, minus the branching loss (in dB) marked on the panel, equals actual transmit output power.

(1)	Power meter indication	=	+5.0dBm
(2)	Loss marked at monitor	=	18.2dB
(3)	Branching Loss	=	-2.2dB

	Output Power	=	+21.0dBm

AGC/ALC Adjustment

- There are two field-adjustable potentiometers on the amplifier (shown in Figure 2.4). The repeater Output level and Nominal gain is adjusted by AGC/ALC potentiometer. The other potentiometer is for Maximum Gain adjustment, which is left at minimum attenuation by the factory. If for any system requirement, the maximum (linear) gain of the repeater can be reduced by this potentiometer. However, any reduction of the maximum gain of the repeater will also reduce the AGC/ALC range of the repeater by the same amount. For various options of repeaters, with the same operation point, input/output power level, they will have the same AGC dynamic range. However, more complex options have higher branching loss, hence less maximum available gain. Therefore they will have less downfade reserve, dB to dB.

Power Supply

- The only active elements in the RF-1500E assembly are the amplifiers which operate from a +13.5 Vdc source. Current

requirements are 1.0 Amperes per amplifier. The repeater assembly may be powered from solar panels/batteries, primary cells only, or from an ac/dc supply with standby battery (shown in Figures 2.5 and 2.6). 3A fuses are used.

- Storage batteries and solar cell panels are selected on the basis of the average solar intensity and temperature range at the site. The batteries are engineered to provide the required reserve capacity across the temperature range and during periods when the output from the solar panels is low or not available. Controllers are used with the solar panels to efficiently charge the batteries without overcharging. Peninsula Engineering can determine the solar and battery capacity. The location of the site should be specified when requesting assistance.

- In areas where commercial power is available, an ac power supply can be provided. Although one ac power supply will provide ample current to power all amplifiers, dual AC power supplies are recommended for higher reliability. The dual AC power supply system also contains two charge controllers and two sets of standby batteries to provide power during AC power failures. Each battery is float charged while the power supply is on and has 100 amp-hours as standard capacity. Additional batteries can be purchased if the system requirement needs them.

- In locations where commercial power is not available and solar panel charging is impractical, primary cell batteries capable of powering an RF-1500E repeater in excess of a year are available. In such applications, the battery installation should be given an environmental shelter according to the manufacturer's recommendations.

3. ALARMS (Optional)

- The RF-1500E repeater can be provided with an optional alarm system to remotely monitor the repeater site. Conditions that are typically monitored are listed below:

Standard Telemetry:

- a) A and B Battery Voltage
- b) Battery Temperature

Standard Trip Points:

- c) A and B Battery Major Alarm (2)
- d) East and West RF Output Low (2)

RF-1500E Repeater

- e) Amplifier Alarm
- f) Cabinet Door Open
- g) Feedline pressure low
- h) 6 Each User Points, Strappable:
Closed or Open = Alarm

• The alarms are relayed back to the terminal through the use of a low rate telemetry signal directly modulated on the RF in a noninterfering fashion. Alarms are visually displayed on the terminal receiver unit. Alarm contact closure outputs are available for input to standard microwave supervisory systems.

4. LICENSING

(Reserved)

5. ORDERING

• The RF-1500E RF Repeater Assembly is ordered by specifying the system model number RF-1500E-XX (Tables 5.1). Spare amplifiers and in-service amplifier change kit (Ref. Sec.

8.07) are listed in Table 5.2. Attenuators are provided by specifying their part numbers. Transmission engineering must be completed before ordering because the necessary attenuator values are determined from the path calculations. Part numbers are listed in Table 5.3.

• When doing the initial system layout of a radio hop which includes a RF-1500E RF Repeater Assembly, several factors must be considered prior to ordering, to ensure correct antenna connections.

- (a) Terminal transmit-Repeater receive frequencies (F1 and F2 or F1, F3 and F2, F4).
- (b) Physical mounting of RF-1500E repeater on tower (or crossarms) in relation to mounting of antennas.

• The RF-1500E repeater may be factory-tuned so that f1 RCV (LEFT) associates with the lower of the two frequencies and f2 RCV (RIGHT) with the higher; or vice versa. By comparing the factors listed above, correct antenna/coaxial feeding connections will result. The equipment order must specify the f1 and f2 frequencies. for example:
f1 RCV = 1450MHz and f2 RCV=1499MHz or
f2 RCV = 1499MHz and f2 RCV=1450MHz

Table 5.1
RF-1500E RF Repeater Ordering Information
Frequency Range: 1.427~1.535 GHz

Standard Assembly	Part Number	Description	Frequencies (MHz)
RF-1500E-01	900-0967-01	Duplex	F1 F2
RF-1500E-02	900-0967-02	Duplex, Frequency Diversity	F1 F3 F2 F4
RF-1500E-03	900-0967-03	One-Way	F1

Table 5.2
Spare/Replacement Amplifier Ordering

Description	Stock Number
Amplifier	090-0966-01
Sparing Kit	091-0005-01

Table 5.3
Coaxial Attenuator

Stock Number	Attenuation	Part Number	Attenuation
149-0128-01	1.0dB	149-0128-11	11.0dB
149-0128-02	2.0dB	149-0128-12	12.0dB
149-0128-03	3.0dB	149-0128-13	13.0dB
149-0128-04	4.0dB	149-0128-14	14.0dB
149-0128-05	5.0dB	149-0128-15	15.0dB
149-0128-06	6.0dB	149-0128-16	16.0dB
149-0128-07	7.0dB	149-0128-17	17.0dB
149-0128-08	8.0dB	149-0128-18	18.0dB
149-0128-09	9.0dB	149-0128-19	19.0dB
149-0128-10	10.0dB	149-0128-20	20.0dB

149-0128-XX Coaxial Attenuator. Equipped with SMA male and female connectors. May be inserted in receive line or transmit line for RF level coordination.

Table 5.4
Alarms Ordering, RMAS-100 Alarm System

Standard Assembly Stock Number	Repeater Configuration
900-0040-05	1 + 0
900-0040-07	1 + 1

One alarm transmit module can send information to terminals at one or both ends of the Repeater Link. Order receive modules for one or two locations as needed.

- Alarm system is optional. It should be ordered according to Table 5.4.
- Orders should include a shipping destination and a billing address. Upon receipt of your order, Peninsula Engineering returns an acknowledgment with the scheduled shipping date. An equipment list showing the equipment ordered and shipped, is included with the shipment.

- When the RF-1500E equipment is received, inspect it carefully for damage. Claims for damage should be reported directly to the transportation company involved immediately, in accordance with their instructions.

- The RF-1500E assembly can be mounted on crossarms on a wood-pole structure, a steel tower, or on a wall. At extremely hot environment, eg. desert, shading from direct sunshine may be required. The length of all power leads should be limited and the wire size adequate to minimize the voltage drop. The repeater assembly, battery boxes, solar panels, and antennas should all be mounted before any wiring is done. Mounting hole dimensions for the repeater housing are shown in Figure 6.1.

6. INSTALLATION

General

(All installation here refers to 12 VDC power supplies)

FIGURE 2.4

AMPLIFIER

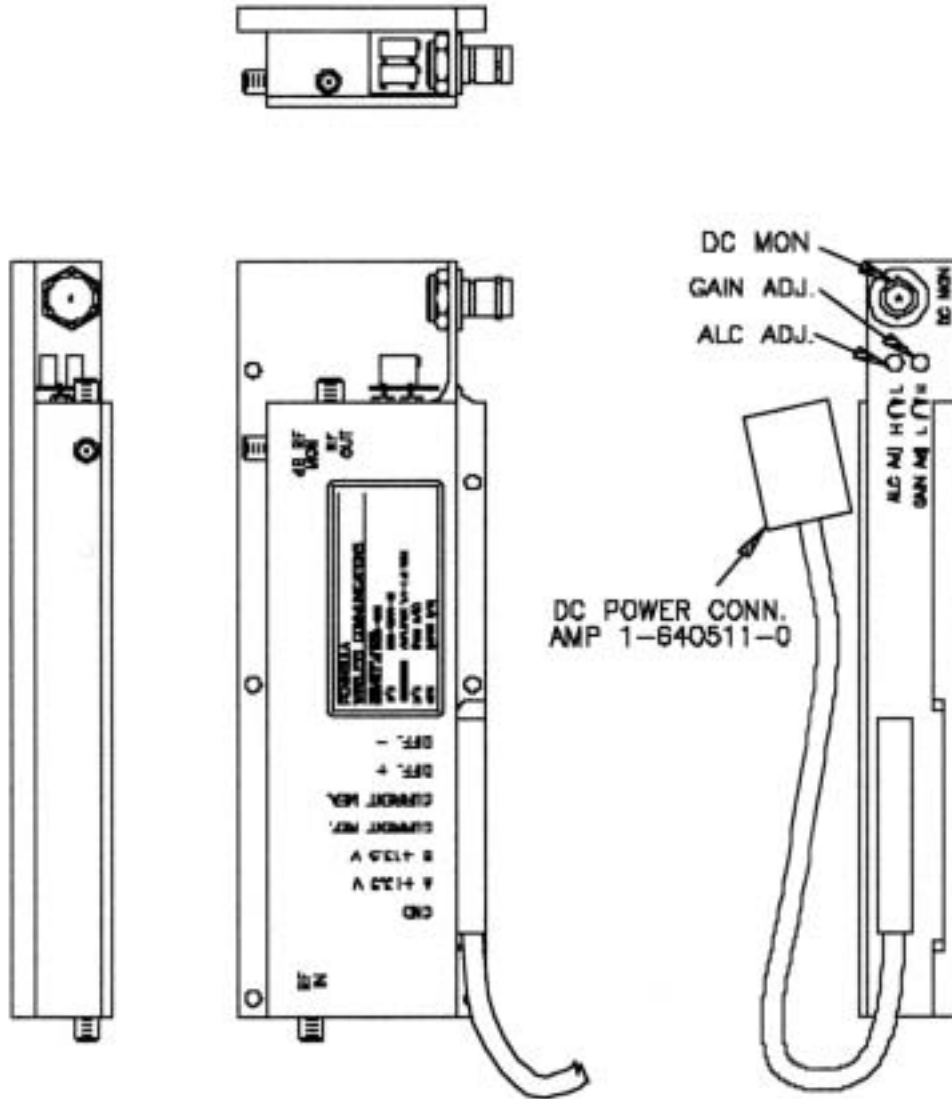

PIN ASSC.

#	FUNCTION
1	GND
2	+13.5V, PRI
3	+13.5V, SEC
4	AMP CURRENT REF
5	AMP CURRENT MEAS
6	DIFF ALARM SIGNAL IN (+)
7	DIFF ALARM SIGNAL IN (-)

FIGURE 2.5 POWER BLOCK DIAGRAM

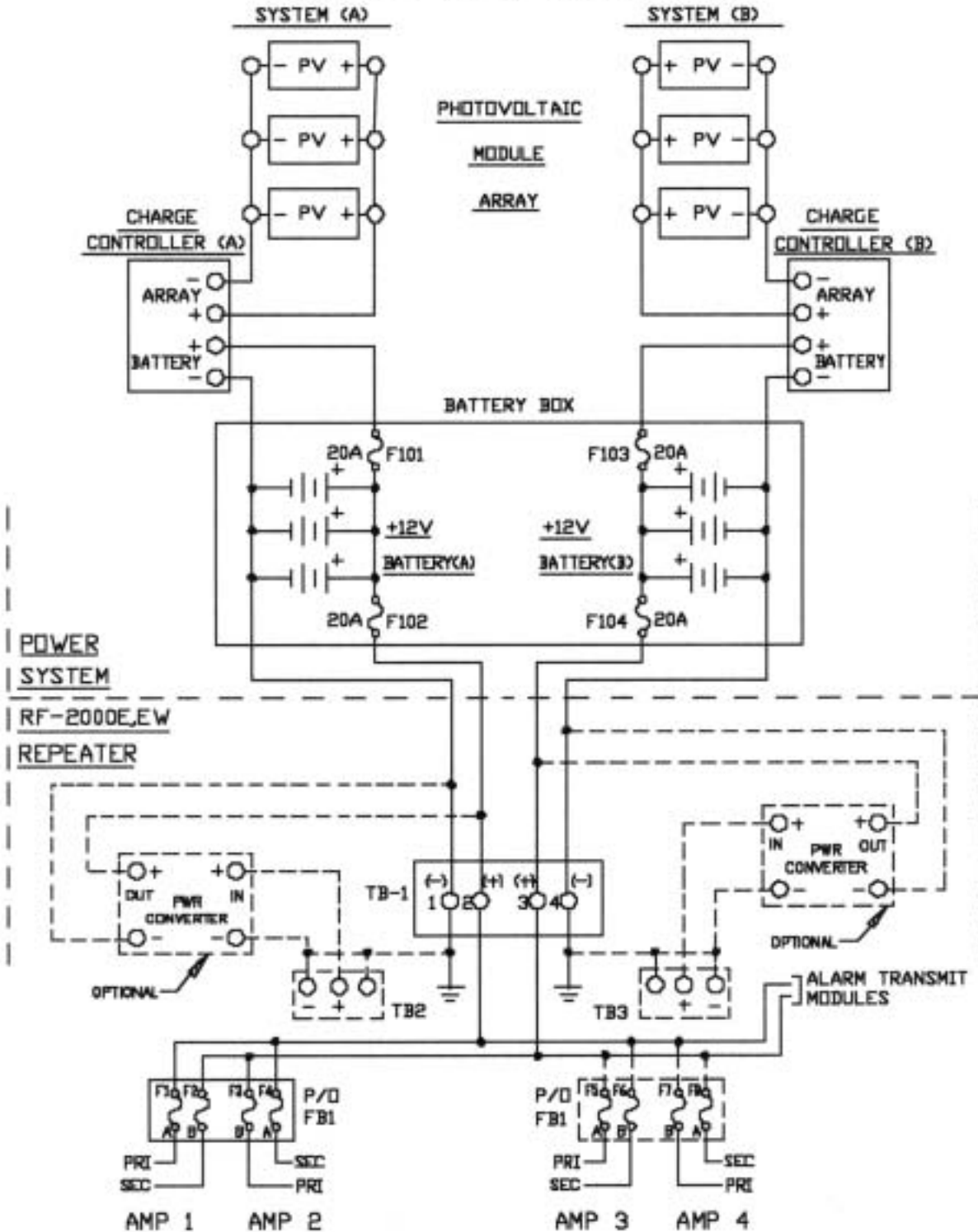

FIGURE 2.6
REPEATER POWER WIRING PICTORIAL

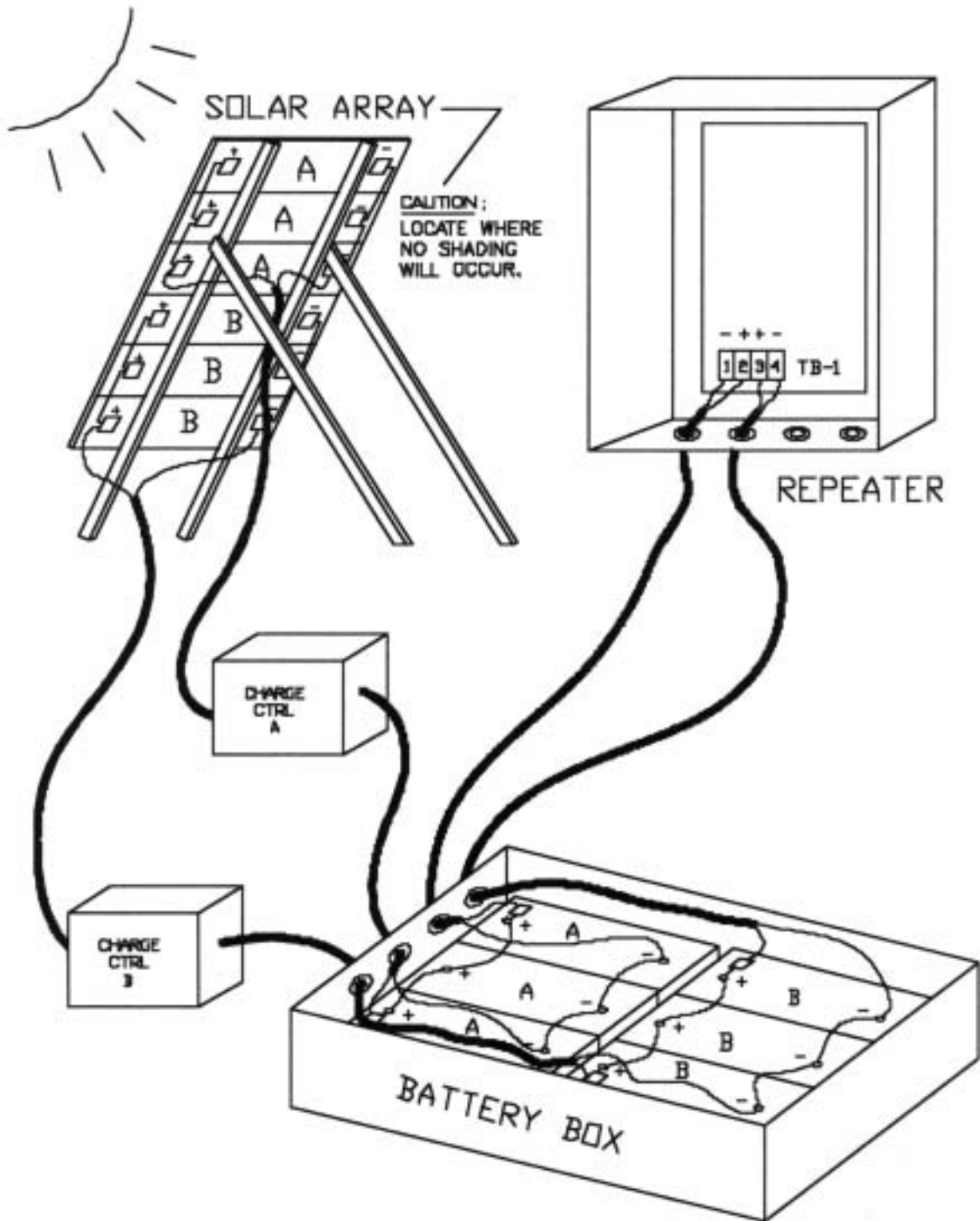
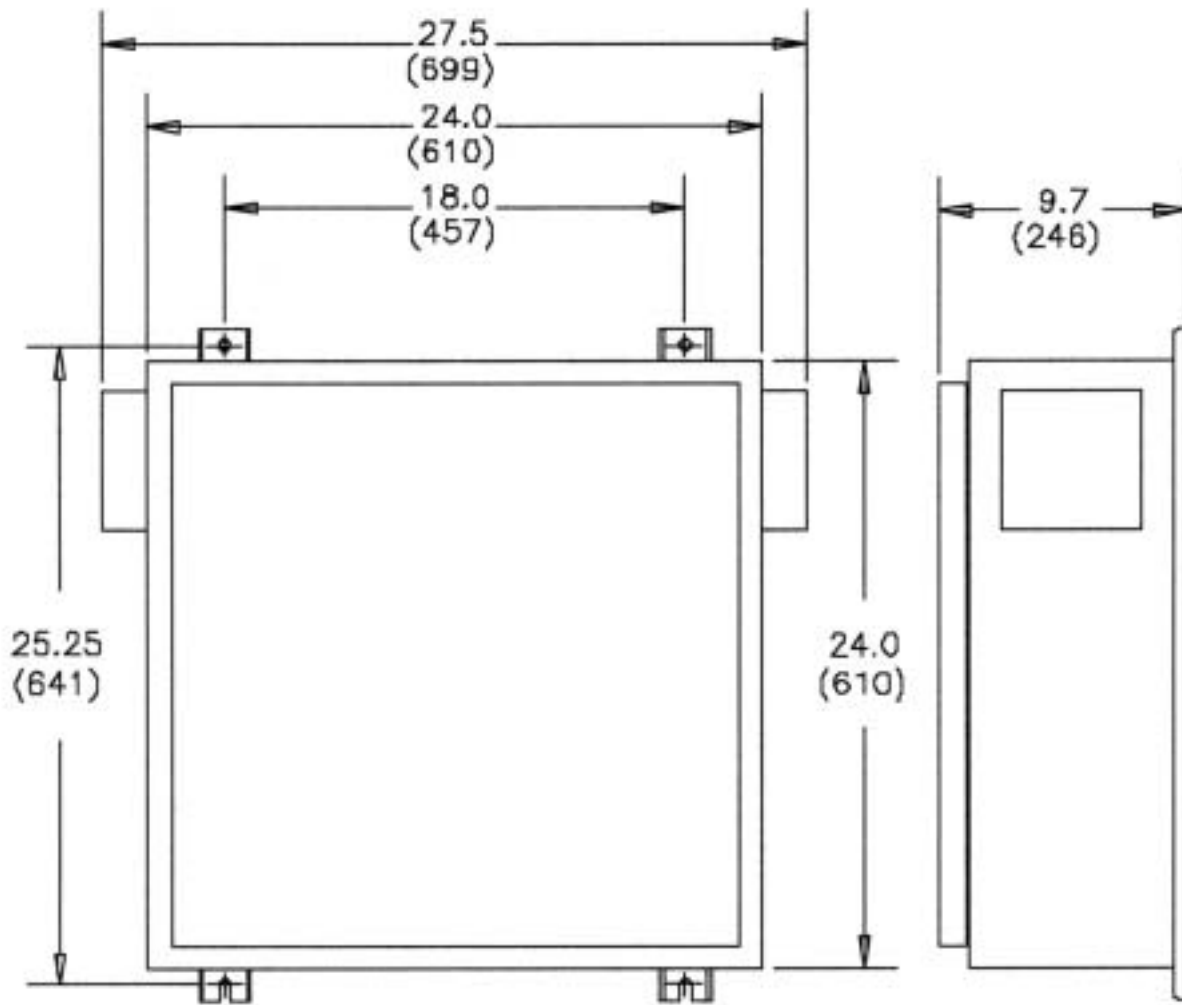

FIGURE 6.1
CABINET MOUNTING DIMENSIONS



MOUNTING HOLES ARE .44 DIA.(112)

DIMENSIONS ARE IN INCHES (mm)

FIGURE 6.2
ANTENNA COAXIAL CONNECTIONS

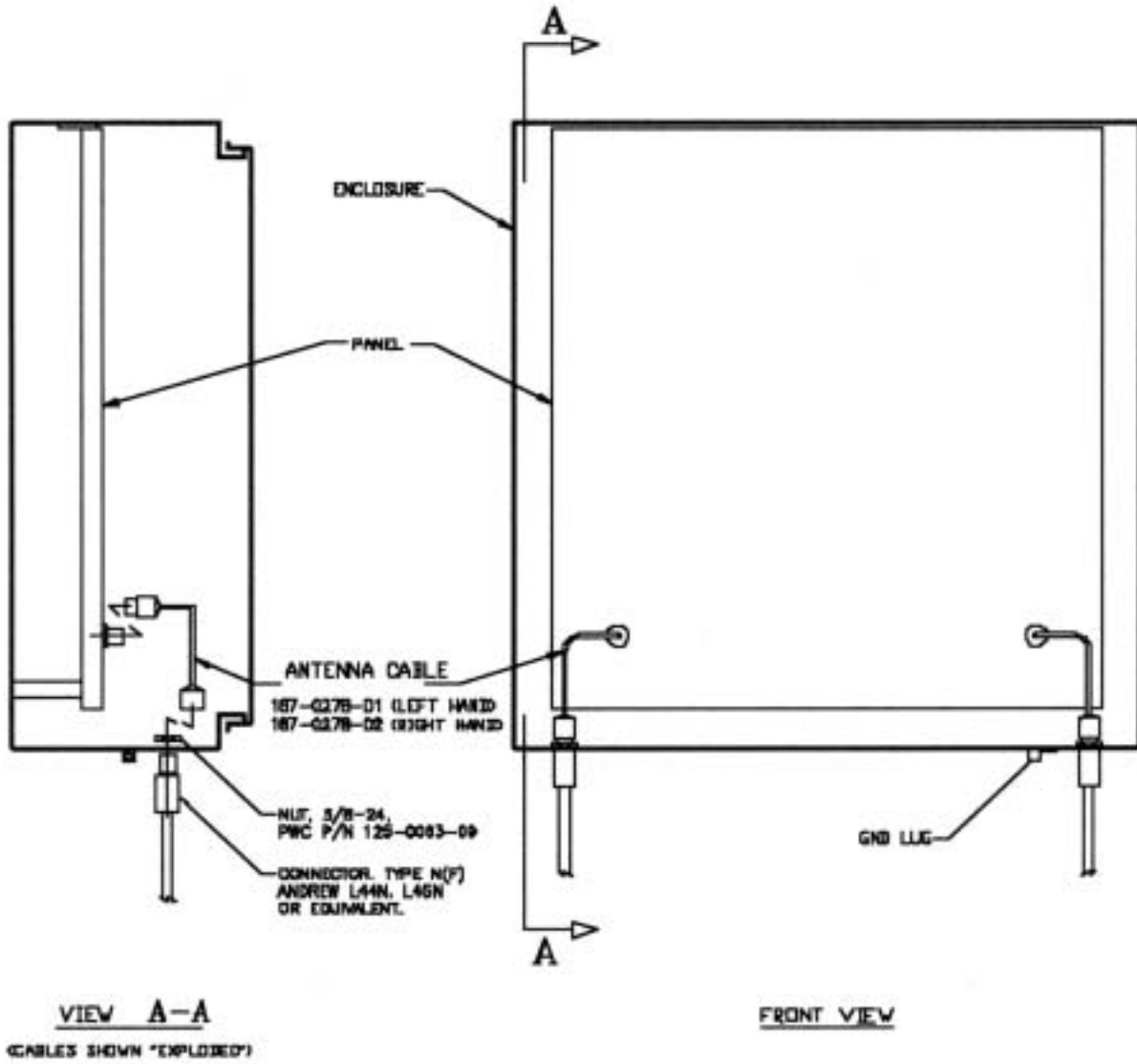

- Prior to cutting to length and connecting the coaxial feedlines, verify which repeater receive frequency associates with each antenna port. The repeater receive frequencies are marked on the repeater panel by each "N" type connector.

- The coaxial feedlines are terminated in type N(female) connectors with extended threads. The threaded end mounts in a hole in the cabinet bottom with a 5/8-24 UNEF (Type N), PWC P/N 125-0063-09 nut. The connector type is Andrew P/N L45N or equivalent. A jumper of semirigid coax (Figure 6.2) is provided to connect from the feedline connector to the panel connector (Left: 187-0278-01 and Right: 187-0278-02).

TO ENSURE TIGHT CONNECTION, DO NOT USE ANY WASHERS OR SPACERS BETWEEN CABINET AND NUT.

Power Wiring

- Remove the fuses from the holders in the battery boxes, if storage batteries are used. The power leads can be brought into the repeater housing through the 1/2 inch (13- mm)-non-metallic conduit (NMT) fittings provided. Use paired 10-gauge (2.50-mm) wire from the batteries to the repeater terminal block and from the solar panels to the charge controller terminal block. Connect the NEGATIVE leads to terminals 1 and 4 of terminal block TB-1 as shown in Figures 1.1, 1.2 and 2.5. If a single ac supply is used, jumpers must be installed between terminals 2 and 3 on the lower side of the terminal block as shown in Figures 1.1 and 1.2. The NEGATIVE power lead is then connected to terminal 1 or 4 as shown. Note that the equipment uses a negative ground.

DO NOT CONNECT ANY POSITIVE POWER LEAD TO TB-1 AT THIS TIME.

Application of power is covered in paragraph 7.

DC Power

- The repeater is normally powered from a dual battery system designated "A" and "B." The "A" battery is wired to power the "A" side of the equipment. Similarly, the "B" battery is wired to power the "B" side of the equipment. Standby power switchover is accomplished within each

amplifier. Each amplifier has a primary and secondary battery in-put. If the primary battery should fail, operation will immediately continue on the second-dary battery.

7. TESTS

General

- Few adjustments are required on the RF-1500E repeater. After application of power, AGC/ALC adjustment, and proper antenna orientation, the equipment is ready to be placed in service. Use of portable or mobile radio to establish a talk path between the RF-1500E repeater site and the terminals, will aid in completing the tests and in verification of normal (calculated) system operation.

Test Equipment

- The description of test equipment in Table 7.1 includes the manufacturer's type/model numbers that are available as of the publication date. Since certain models of test equipment may become discontinued or super seded by the manufacturer at any time, it is recommended that a manufacturer's current catalog be used when ordering the equipment. The test equipment manufacturers listed are for reference only and are not intended to show a preference for any one manufacturer. Equivalent test equipment may be used unless otherwise noted. Regardless of the test equipment used, it must be properly maintained, calibrated, and operated according to instructions given by the manufacturer.

Application of Power

- If solar panels and storage batteries are used, measure the voltage across Charge Controller input terminals (+) and (-). Confirm the proper polarity. The voltage reading should be between +12 and +17 Vdc. If the polarity is incorrect or there is no voltage, check and correct the wiring to the solar cell panels. If the voltage is low, check to be sure the surfaces of the solar panels are not obscured from sunlight. Next, remove battery input fuses F101 and F103. Battery output fuses should now be in place. Measure the voltage across terminals 1 (-) and 2 (+) and across terminals 3(+) and 4 (-) of repeater terminal block TB-1. Confirm the proper polarity. The voltage reading should be +12.5 to +13.5 Vdc for

RF-1500E Repeater

storage batteries or +13.0 to +15.0 Vdc for an ac power supply. If the polarity is incorrect or there is no voltage, check and correct the wiring of the batteries or ac power supply. Replace battery fuses F101 and F103.

- Set the digital voltmeter (dvm) to read in a range of 5A or greater and put its test leads in series between positive lead from battery system A and terminal 2 (+) of TB-1 on the repeater (Figures 2.5, 2.6). After the current stabilizes in half a minute, the current should be within the limits as shown in Table 7.2. Log all voltage and current readings in Table 8.1 for reference during routine maintenance or trouble location procedures.

Table 7.2
Current Requirement
with One Power Supply On

RF-1500E-01	1.9 ~ 2.0A
RF-1500E-02	3.7 ~ 4.0A
RF-1500E-03	93 ~ 1.0A

- Repeat the above procedure to measure current from battery system B and terminal 3 (+) of TB-1 on the repeater.

The current should also be within the limits as shown in Table 7.2. Log them in Table 8.1.

- Connect the positive lead from battery system B to terminal 3 (+) of TB-1. Make current measurement from battery system A to terminal 2 (+) of TB-1. The current reading should be within the limits as shown in Table 7.3. Log in Table 8.1. Connect the positive lead from battery system A to terminal 2 (+) of TB-1.

Table 7.3
Current Requirement on One Power
Supply with Both Power Supplies On

RF-1500E-01	1.0 A Max.
RF-1500E-02	2.0 A Max.
RF-1500E-03	1.0/0 A Max.

Antenna Isolation Measurement

- In order to prevent oscillation or severe passband distortion, the antenna must have a minimum port-to-port isolation. Please refer to Appendix A for detail information.

Table 7.1
Recommended Test Equipment

Item	Manufacturer and Type Number	Use	Quantity
DVM	Fluke 75 or equivalent	Measure 12 to 15 Vdc and current from 150mA to 5A	1
RF Power Meter	Hewlett-Packard 435B equipped with 8481A or equivalent	Antenna orientation and output power measurements (-10 to +25 dBm)	1
Spectrum Analyzer	Hewlett-Packard 8563A or equivalent	Antenna orientation	1
Attenuator	Microlab/FXR AJ-500F, 30 dB or equivalent	Antenna orientation and power alarm set (RMAS-110)	1

- Measure the isolation by sending a signal into one of the antenna feeders and measuring the level of that signal at the other antenna feeder. The signal power level difference in dB is the isolation of two antenna.
- Be aware that the motion of objects near to the antenna can change the isolation. Tests should be made with any expected objects present, if possible, to ensure that the isolation does not drop below minimum.
- Repeat the test at several frequencies across the designated bandwidth, making sure the minimum isolation is met at ALL frequencies.
- If isolation is not met, try repositioning the antenna, or adding intervening shielding and then measure again.

Antenna Orientation, AGC/ALC set and Output Measurement

- Before antenna orientation begins, the amplifiers must be operating in their full gain mode (out of AGC/ALC range). The setting of the AGC/ALC along with a high input level (greater than [desired output power level in dBm - 60 dB]) may cause the normal action of the AGC/ALC circuit to mask changes in power due to azimuth and elevation sweeping of the antennas. The output power of an amplifier will increase in level as the input level is increased to the point where the AGC/ALC has been set (eg. +18 dBm for 16QAM on Power Level 1). Further increases in input level will be absorbed in the AGC/ALC circuit. To use the amplifier power monitor point as a signal strength indicator, turn Variable Gain pot counter-clockwise to reduce the linear gain of the repeater such that the output is below the desired level. Its AGC/ALC function is disabled now. If during antenna orientation, the power rises to the desired power level, turn the Gain Adjustment counter-clockwise further to reduce the output level again and then continue with antenna orientation. Same result can be achieved by reducing the input level by adding attenuators at the input of the amplifier.
- Connect the spectrum analyzer (Power Meter may be used in emergency situations.) to the f1 amplifier, A1, RF PWR MON port. With a signal transmitted from the A terminal, position the A antenna for a maximum power reading on the meter or analyzer. Turn Gain Adjustment fully clockwise and remove any temporarily installed input attenuators. Reset the

power level with the AGC/ALC adjustment if needed. The AGC/ALC adjustment is located near the out-put end of each amplifier, see Fig.2.7. Use screw driver to adjust the AGC/ALC potentiometer CW to reduce the power setting or CCW to increase the AGC/ALC set point. Log the power reading to fulfill FCC requirements. Move the spectrum analyzer from the f1 Amplifier PWR MON to the f2 Amplifier PWR MON. With a signal transmitted from the B terminal, position the B antenna for a maximum power reading on the meter or analyzer. Turn Gain Adjustment fully clockwise and remove any temporarily installed input attenuators. Set the power level with the AGC/ALC adjustment if needed. Log the power reading to fulfill FCC requirements. Measure and log the power at any additional amplifier directional couplers so equipped (f3, f4...). Remove the analyzer.

- After the antenna orientation has been completed at both terminals and the repeater, AGC readings should be taken at the end terminals and logged for reference. A maintenance test record is shown in Table 8.1.

RX/TX Pad Installation

- If required in the field, the RX/TX pads should be installed at the RF input or out-put of amplifiers. To install it, turn off the DC power supply first. Disconnect the input/output semi-rigid cable from the amplifier. Connect the SMA male end of the pad to the amplifier SMA female input/output; and then connect input/output cable to the other end of the pad. Check all coaxial connections for tightness (8 in-lbs). Set output power level by adjusting AGC/ALC.

8. MAINTENANCE

Routine Maintenance

- Unless unique conditions require more frequent maintenance, routine maintenance should be performed annually. Clean the surfaces of the solar cell panels with isopropyl alcohol or a mild detergent solution. Do not use alcohol compounds containing acetone. Check and clean the wiring connections to the solar charge controllers and the battery connectors as necessary. Follow the procedures as stated in Sections 7.03 through 7.06, measure the current of the repeater system. The current reading should be within the same limits. Also measure the power level

at PWR MON of each amplifier with a power meter. Log current and power reading in Table 8.1.

Administration Requirements

- The Local Telecommunications Administrations may require measurement of the output power of the repeater at installation or when any changes are made which cause the output power to change. Using the power meter, measure and log the output power in Table 8.1 as indicated in paragraph 8.01.

Trouble Location

- Soft failure of one amplifier will be indicated by a drop of approximately 6 dB in the received signal level at the terminal in the direction of transmission, which will be indicated on the AGC meter on the terminal equipment. Amplifiers equipped with AGC/ALC may correct for this drop. The failure of one amplifier will most likely be caused by a failure of DC power to the amplifier. Using the DVM, check for presence of dc voltage at the amplifier power feed through connections.

- If the received signal at the terminals is low but does not indicate a complete failure on one amplifier, the most likely cause is low voltage from the batteries. Low voltage is an indication of a possible battery failure, or a failure of the charging system. In the case of the primary cell batteries, the batteries are probably reaching the limit of their life. Check the batteries and all power lead connections. If solar panels are used, be sure they are not obstructed from sunlight and that the surfaces are clean. If an ac power supply is used, low voltage is probably the result of a power failure, the duration of which exceeded the reserve power limits of the standby battery. Check the standby battery in accordance with the instructions given by the manufacturer of the power supply.

Amplifier Replacement, Out of Service

- When an amplifier must be replaced in an Out of Service condition, do the following:
 - a) Unplug amplifier's power connector.
 - b) Disconnect input and output SMA cables.
 - c) Disconnect BNC cable from DC monitor point.
 - d) Remove mounting hardware (6 screws).
 - e) Remove amplifier.

- To install the replacement amplifier:
 - a) Mount the amplifier on the panel securing with mounting hardware.
 - b) Connect the BNC cable to DC monitor point.
 - c) Connect input and output SMA cables.
 - d) Check all coax connections for tightness (8in/lbs)
 - e) Plug-in the amplifier's power connector.
 - f) Verify operation by measuring power at SMA power monitor (SMA connector).
 - g) Set output power by adjusting AGC/ALC.

Amplifier Replacement, In Service

- For Repeater with 1 or 2 Amplifiers only, such as: RF-1500E-01, -03

- When an amplifier must be replaced while the repeater is in service (eg. soft fail-ure), do the following:
 - a) Mount a temporary spare amplifier in and oriented in the same input/output direction as the amplifier to be replaced.
 - b) Remove the SMA terminations from the coaxial circulators in series, identified by F1 or F2, with the amplifier to be replaced (shown in Figure 1.1).
 - c) Connect the flexible coaxial cables or semi-rigid coaxial cables (part of the sparing kit) from the input(RX) coax circulator open port to the temporary spare amplifier's input SMA. Likewise connect the output(TX) coax circulator open port to the temporary spare amplifier's output SMA connector.
 - d) Connect the DC leads from the temporary spare amplifier using the power adapter in the sparing kit to the "A" battery if replacing amplifier A1, or "B" if replacing amplifier A2.
 - e) Disconnect the input coaxial cable from the amplifier to be replaced. The signal is now carried in the temporary spare amplifier, but may be 20 dB down.
 - f) Unplug the power connector of the amplifier to be replaced.
 - g) Disconnect the output coaxial cable from the amplifier to be replaced.
 - h) Re-set the output power of the temporary spare amplifier by adjusting its AGC/ALC.
 - i) Move BNC cable from DC monitor point of the replaced amplifier to the temporary spare amplifier.

j) Unscrew mounting hardware (6ea) and remove the defective amplifier.

- To install a replacement amplifier in service:
 - a) Mount the amplifier on the panel securing with mounting screws.
 - b) Connect BNC cable to DC monitor point.
 - c) Connect the output coaxial cable to the replacement amplifier's output. Signal level will drop 20 dB.
 - d) Plug in the amplifier's power connector.
 - e) Connect the input coaxial cable to the replacement amplifier's input. Signal level should be close to normal. Set power by adjusting AGC/ALC.
 - f) Remove the power connections from the temporary spare amplifier.
 - g) Disconnect the flexible or semi-rigid coax cables from the coax circulators and from the temporary spare amplifier.
 - h) Replace the SMA terminations on the coax circulators. Check the output power of the amplifier. Re-set its power by adjusting AGC/ALC if needed.
 - i) Remove the temporary spare amplifier.

CAUTION

When operating with a temporary spare amplifier, due to unpredictable reflections within the RF-1500E, its performance may be degraded somewhat from normal; particularly in high capacity digital and analog systems. Be sure the

AGC/ALC is set for the correct power level in your system.

Return Procedure

- Once it is determined that a unit is faulty, contact the Peninsula Engineering Repair Department at: 1-925-901-0103. A representative will issue a Return Authorization Number (RMA) and shipping instructions.

- You will be asked to provide the following:

- Contact name
- Contact's fax number
- Bill to and ship to addresses
- Part number
- Serial number of the problem unit
- Description of the problem unit
- Purchase order number if unit is more than two years old
- Summary of the units problem

- A copy of the RMA will be sent to the contact. This copy, (and a Purchase Order, if required) should be sent in with the unit to PWC.

- Re-ship the units in those containers (if possible) in which the units were originally delivered in order to minimize the potential for shipping damage. Ensure that adequate packing material isolates the unit from undue contact with shipping container. The RMA must be included.

**TABLE 8.1
PENINSULA ENGINEERING
RF-11000 MAINTENANCE RECORD**

Date				
Solar Panel, System A Voltage :				
Solar Panel, System B Voltage :				
Battery, System A Voltage : Temperature :				
Battery, System B Voltage : Temperature :				
Current Drawn From Battery A Only				
Current Drawn From Battery B Only				
Current Drawn From Battery A While Battery B is Connected				
Amplifier, A1 F1 Power Monitor :				
Amplifier, A2 F2 Power Monitor :				
Amplifier, A3 F3 Power Monitor :				
Amplifier, A4 F4 Power Monitor :				

APPENDIX A

Antenna System

The antenna system is vital to the success of any RF repeater. It was only when high performance microwave antennas became available that high capacity RF repeaters became practical. The antennas must have high gain (25-50 dB), clean pattern, low sidelobes and good Front-to-Back ratio. It is the sidelobes and Front-to-Back ratio that control much of the echo that results from antenna to antenna coupling. Foreground obstructions also produce an echo component which is site specific.

The objective for permissible echo varies with the type of transmission and its bandwidth. High capacity analog radios require 50-55 dB C/I while low capacity analog and digital radios require 24-30 dB C/I. The actual amount of echo permitted must be calculated based on the radio manufacturer's specifications and end system design requirements. Table A-1 shows the required RF repeater C/I with different types of radios.

For example, a 1500 4PSK system requires 24 dB C/I at the repeater. The 1.5 GHz RF repeater maximum gain is 60

dB. Antenna-to-antenna decoupling required is $24+60=84$ dB. This can be easily obtained from two 25.8 dB gain focal plane antennas with 41 dB Front-to-Back ratio (F/B). Cross polarization of the antenna is recommended. An antenna Cross Polarization (XPD) of 20 dB is easily obtained. Antenna separation loss of 37 dB is assumed by taking 75% of free space loss between the feeds of the two antennas. The decoupling is now:

+41	dB	F/B of Antenna #1 (standard)
-26	dB	Gain of Antenna #1 (8 foot)
+41	dB	F/B of Antenna #2 (standard)
-26	dB	Gain of Antenna #2 (8 foot)
+20	dB	Antenna XPD
+37	dB	Antenna separation loss (16 feet, 4.9m)
<hr/>		
87	dB	Total decoupling loss
-60	dB	Repeater Gain
<hr/>		
27	dB	C/I

In this situation, if other type of antenna with less front-to-back ratio are used, larger distance of separation may be needed. Or some kind of obstruction can also increase antenna decoupling.

Table A-1

C/I Requirements For Digital Radios

For -1 dB system gain at 10^{-6} BER or $BER < 10^{-12}$ at normal RSL, use following table:

MODULATION TYPE	MINIMUM C/I
4 PSK	24
8 PSK	28
16 QAM	33
64 QAM	40
MSK/FSK	30
9 QPRS/QPR 3	31
25 QPRS/QPR 5	32
49 QPRS/QPR 7	33
81 QPRS/QPR 9	35

Table A-2
C/I REQUIREMENTS FOR ANALOG RADIOS

CAPACITY (CHAN)	DEVIATION	C/I for 10 dBmco IM	C/I fo 20 dBmco IM	C/I for 30 dBmco IM
24-48	50	28	18*	8*
72	50	30	20	10*
96	47/50	32	22	12*
120	200	44	34	24
132	30	40	30	20
252	65	42	32	22
300	200	45	35	25
420/480	200	53	43	33
600	200/141	54	44	34

NOTE*: Operation with C/I less than these required values can cause other problems such as increasing the potential for oscillation and is therefore not recommended.