



no buildings | no roads | no power lines
just great reliability.

World Headquarters

39 Grand Canyon Lane
San Ramon,
CA 94583 USA

President

Frank Martens

Phone

925.901.0103

Fax

925.901.0403

Peninsula Engineering

Solutions, inc. may
change specifications as
necessary to meet
industry requirements.

Website www.peninsulaengineering.com

Email fmartens@peninsulaengineering.com

RF-15000 Repeater

Microwave Repeater Systems

Applications

- Low-cost, highly reliable 15 GHz microwave-through-repeater for extending range of or clearing obstructed microwave radio paths.
- Excellent performance with analog, digital, or video microwave radios.
- Compatible with any manufacturer's 15 GHz radio terminal.
- Solar power compatible—economical in thin routes and remote locations.

Features

- RF output power up to +21 dBm analog FSK, +19 dBm digital 4PSK.
- Power consumption only 1.2 A at 13.5 Vdc for duplex operation.
- Solar powered, AC powered, or powered by primary cells.
- Compact and lightweight—ideally suited for remote sites that do not have access roads or commercial power.
- Environmentally protected aluminum, weathertight, lockable cabinet. No extra environmental shelter required in most installations. Suitable for use at undeveloped sites anywhere in the world—Alaska to Saudi Arabia.
- Internally protected duplex, frequency diversity, and three-way (“Y Junction”) configurations available.
- Only one active element per channel—the internally redundant linear amplifier.
- AGC/ALC provided to correct input fades and reduce overload.
- In the case of single duplex configuration, amplifiers can be replaced without disrupting service.
- RMAS-120 Alarm System (optional), which can remotely monitor the repeater.
- Equipped with directional couplers for in-service RF output power measurements.
- No frequency conversion -- received signal is filtered, amplified, and re-radiated.
- Very reliable, greater than 85,000 hours MTBF for duplex.
- Available as a self-contained RF Repeater for use with customer-furnished antenna and power equipment or as a complete package including repeater, antenna, solar electric panels, battery charger, and batteries.

Table of Contents

APPLICATIONS	01
FEATURES	01
TECHNICAL SUMMARY	02
1. GENERAL	05
2. FUNCTIONAL DESCRIPTION	05
Basic Repeater	05
Amplifiers	05
Directional Couplers	11
AGC/ALC Adjustment	11
Linear Gain Adjustment	11
Power Supply	11
3. ALARMS	11
4. ORDERING	15
5. INSTALLATION	17
General	17
Power Wiring	17
DC Power	19
6. TESTS	19
General	19
Test Equipment	19
Application of Power	19
Antenna Isolation Measurement	20
Antenna Orientation, AGC/ALC set and Output Measurement	21
7. MAINTENANCE	22
Routine Maintenance	22
Administration Requirements	22
Trouble Location	22
Amplifier Replacement, Out of Service	22
Amplifier Replacement, In Service	22
Return Procedure	23
APPENDIX A	25
Antenna System	25

1. GENERAL

- This section provides information about the Repeater Technologies RF-15000 RF Repeater Assembly; hereinafter referred to as the RF-15000. The RF-15000 can be used with any manufacturer's 15 GHz radio, operating in the 14.50–15.35 GHz frequency range, to provide an intermediate repeater.
- The RF-15000 assembly is an RF-through-repeater designed for remote locations. No tuning is required, and the use of highly reliable components and minimum active circuitry eliminates most subsequent maintenance.
- The Repeater assembly is contained in an aluminum, weathertight cabinet. The complete assembly can be wall-mounted, but in most applications, it is pole- or tower-mounted. See Figure 1 and Figure 2 for front views of the repeater in different enclosure sizes.

2. FUNCTIONAL DESCRIPTION

Basic Repeater

- The RF-15000 duplex repeater uses internally redundant amplifiers for transmission in each of two directions. Each amplifier is powered by two separate battery supplies for added reliability. Bandpass filters and circulators, which form a duplexer network, direct the receive signals to the amplifiers and combine the amplifier outputs to a common antenna port for transmission in each direction (see Figure 3 and Figure 4). Dual polarized antenna port repeaters are available.
- The receive signal from the A antenna—identified as frequency f1—enters the repeater through the cabinet-mounted WR62 cover flange and is fed to a RX-TX branching circulator.
- From the channel branching circulator, the f1 signal is passed to the f1 receive bandpass filter.
- The bandpass filter passes the f1 signal to a terminated coaxial circulator and an optional f1 receive pad and then to amplifier 1.
- The amplified signal passes through the optional f1 transmit pad.

- From the transmit pad the f1 signal passes through a terminated coaxial circulator and the f1 transmit bandpass filter to the channel branching circulator, and then to the RX-TX branching circulator. From there, it passes to the cabinet mounted WR62 cover flange for connection to the B antenna.
- In the other direction the receive signal from the B antenna—identified as frequency F2—enters the repeater through the cabinet-mounted WR62 cover flange and is fed to a RX-TX branching circulator.
- From the channel branching circulator, the f2 signal is passed to the f2 receive bandpass filter.
- The bandpass filter passes the f2 signal to a terminated coaxial circulator and an optional f2 receive pad, and then to amplifier 2.
- The amplified signal passes to the optional f2 transmit pad.

- From the transmit pad the f2 signal passes through a terminated coaxial circulator and the f2 transmit bandpass filter to the transmit channel branching circulator, and then to the RX-TX branching circulator and the cabinet mounted WR62 cover flange for connection to A antenna.

NOTE: For duplex systems, additional coaxial circulators are added to input and output ports of amplifiers.

- Receive pads RX f1 and RX f2 reduce the repeater receive signals to approximate the recommended input level. Transmit pads TX f1 and TX f2 reduce the output signal levels of the repeater to prevent overloading of the terminal receiver in a short path. Pads are mounted on input and output of amplifiers. Nominal input and output power levels for various repeater channel configurations are listed in the Technical Summary at the beginning of this manual.

Amplifiers

- In digital radio applications, amplifiers operate at a reduced average power level to meet the output power level requirement as shown in the Technical Summary. This reduced level is to maintain linearity over the entire signaling envelope. Each amplifier is mounted on the cabinet wall to allow convenient AGC/ALC and linear gain adjustments, as

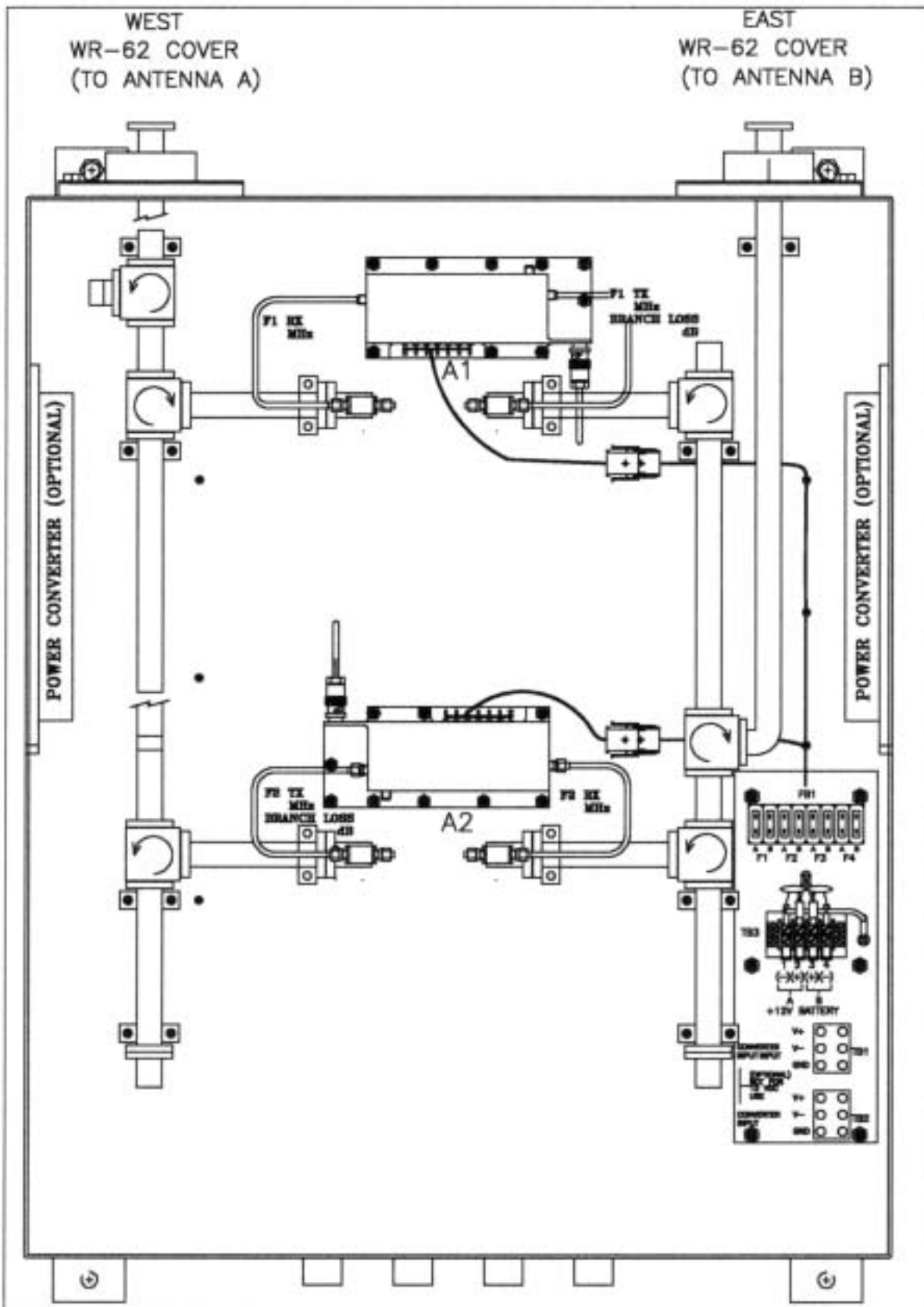

Figure 1. Mechanical Layout (Duplex Repeater)

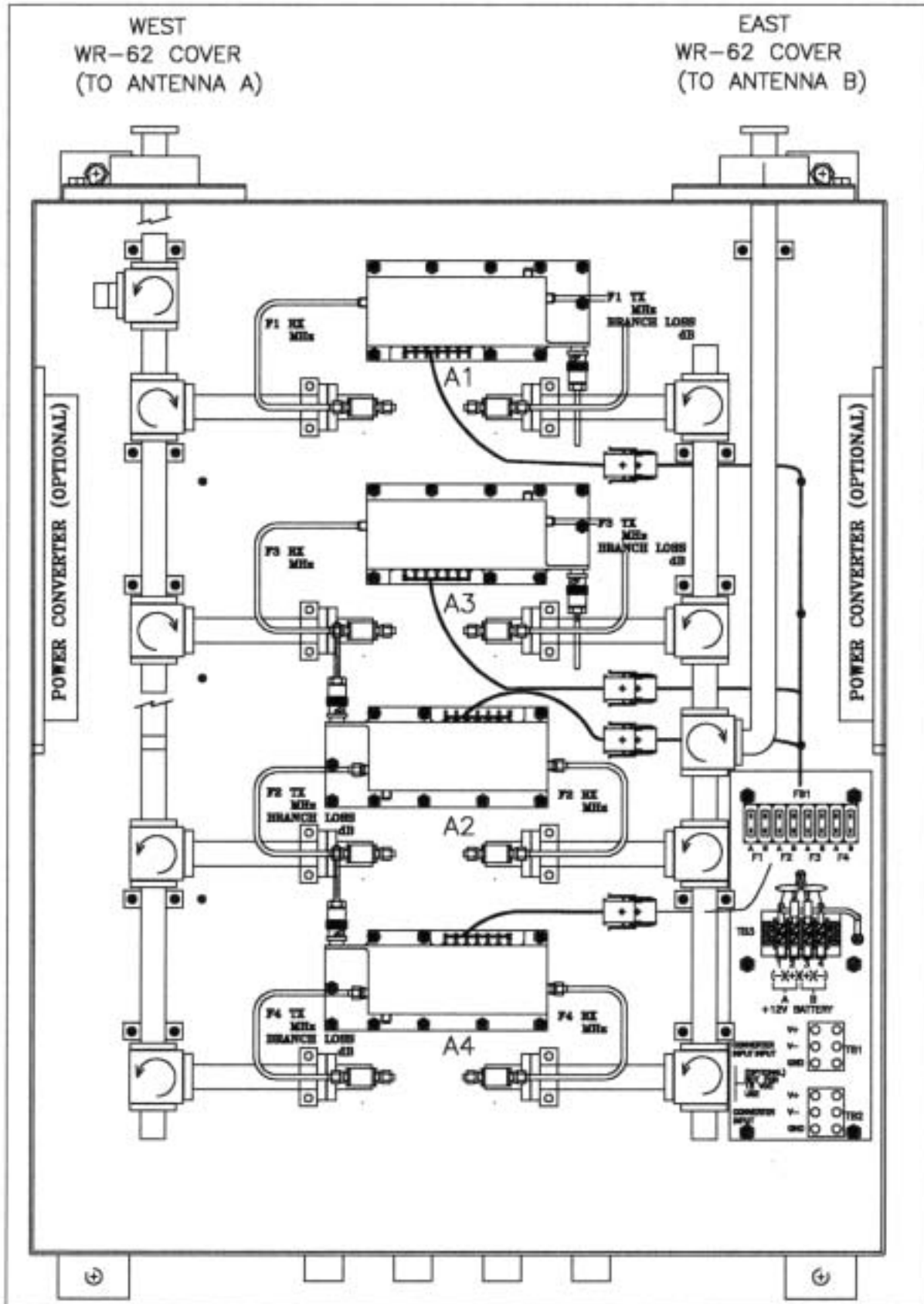

Figure 2. Mechanical Layout (Frequency Diversity)

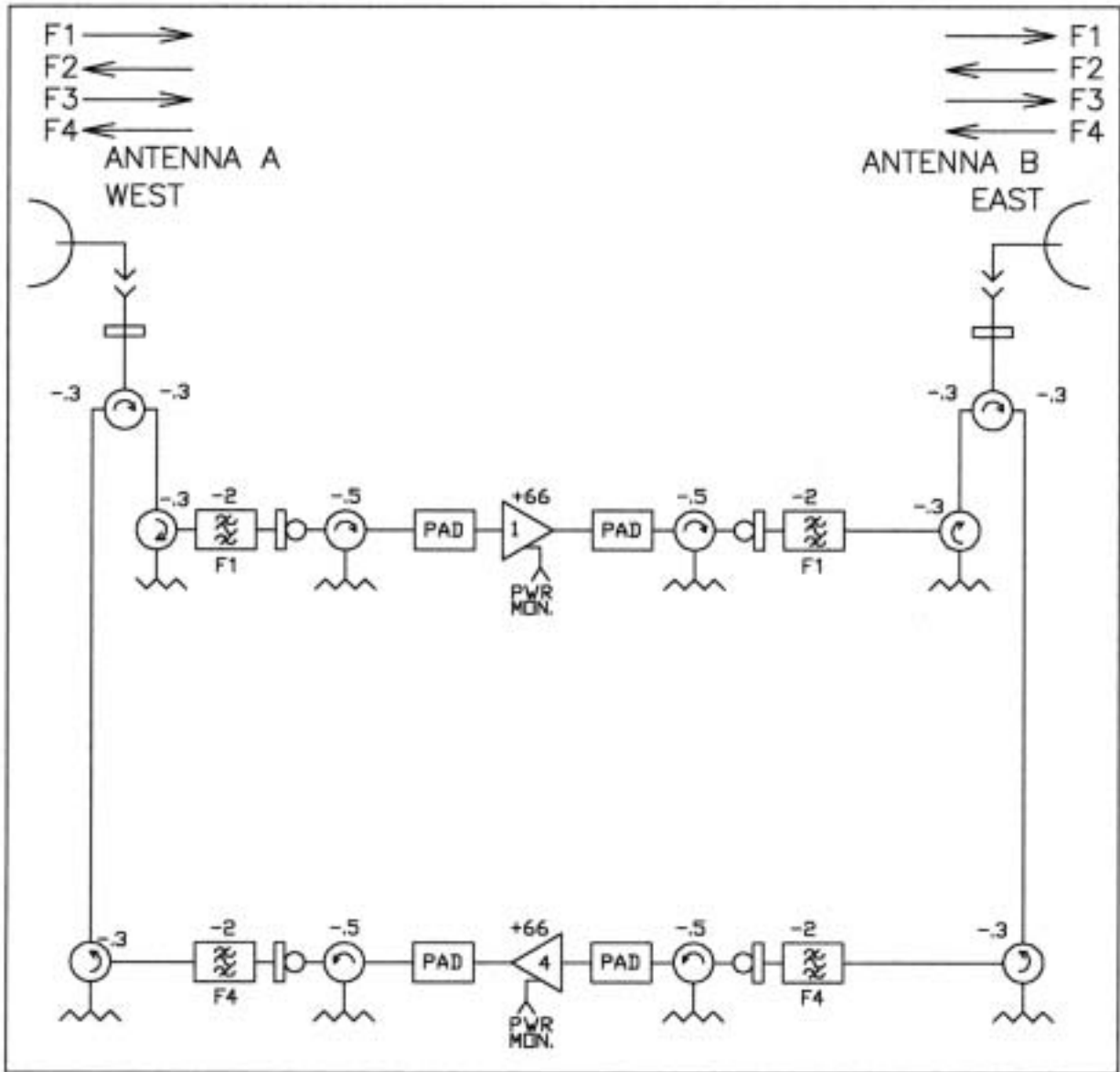

Figure 3. RF-15000-01, (1+0), Equalized (optional pads shown)

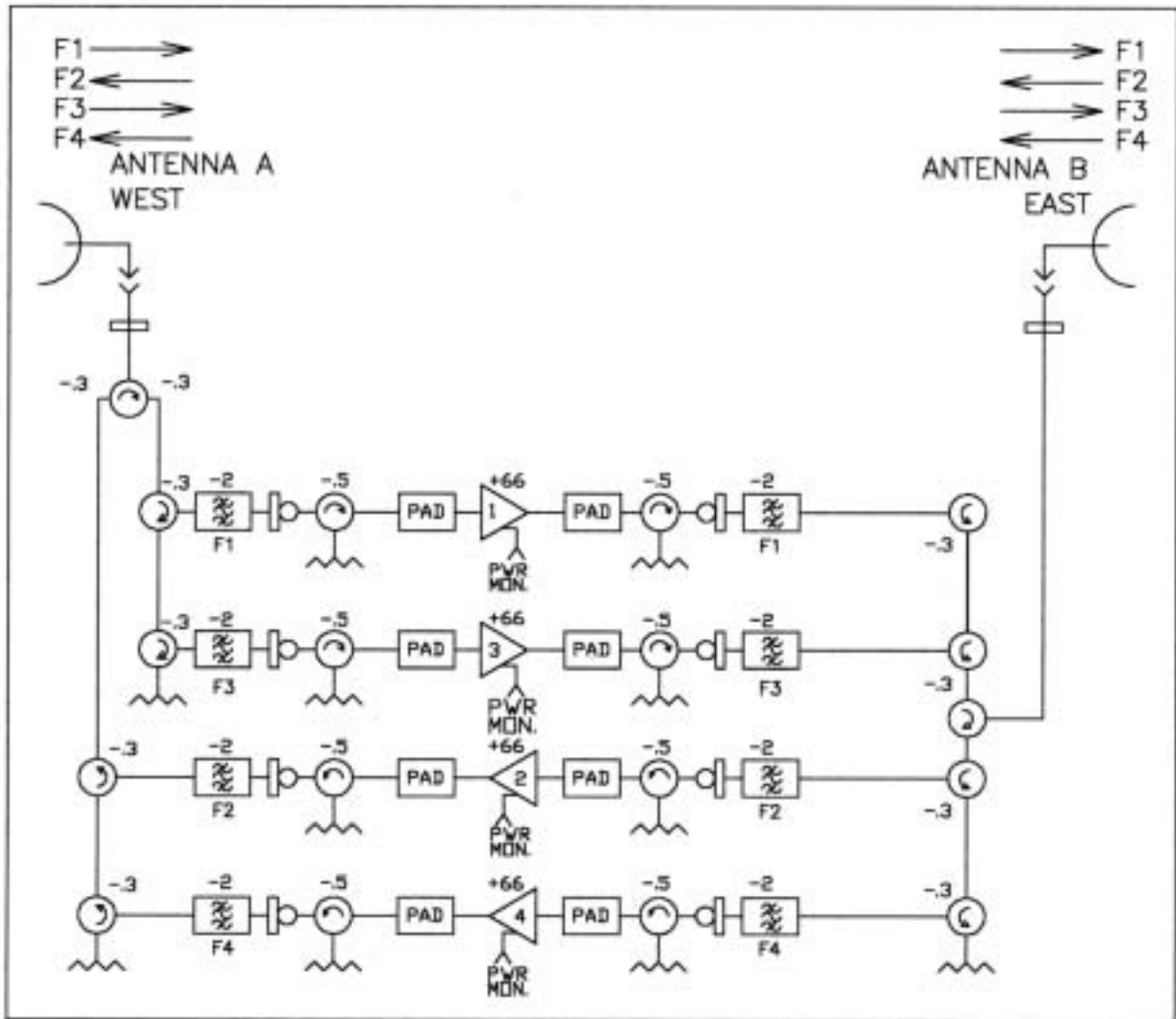

Figure 4. RF-15000-02, (1+1), Equalized (optional pads shown)

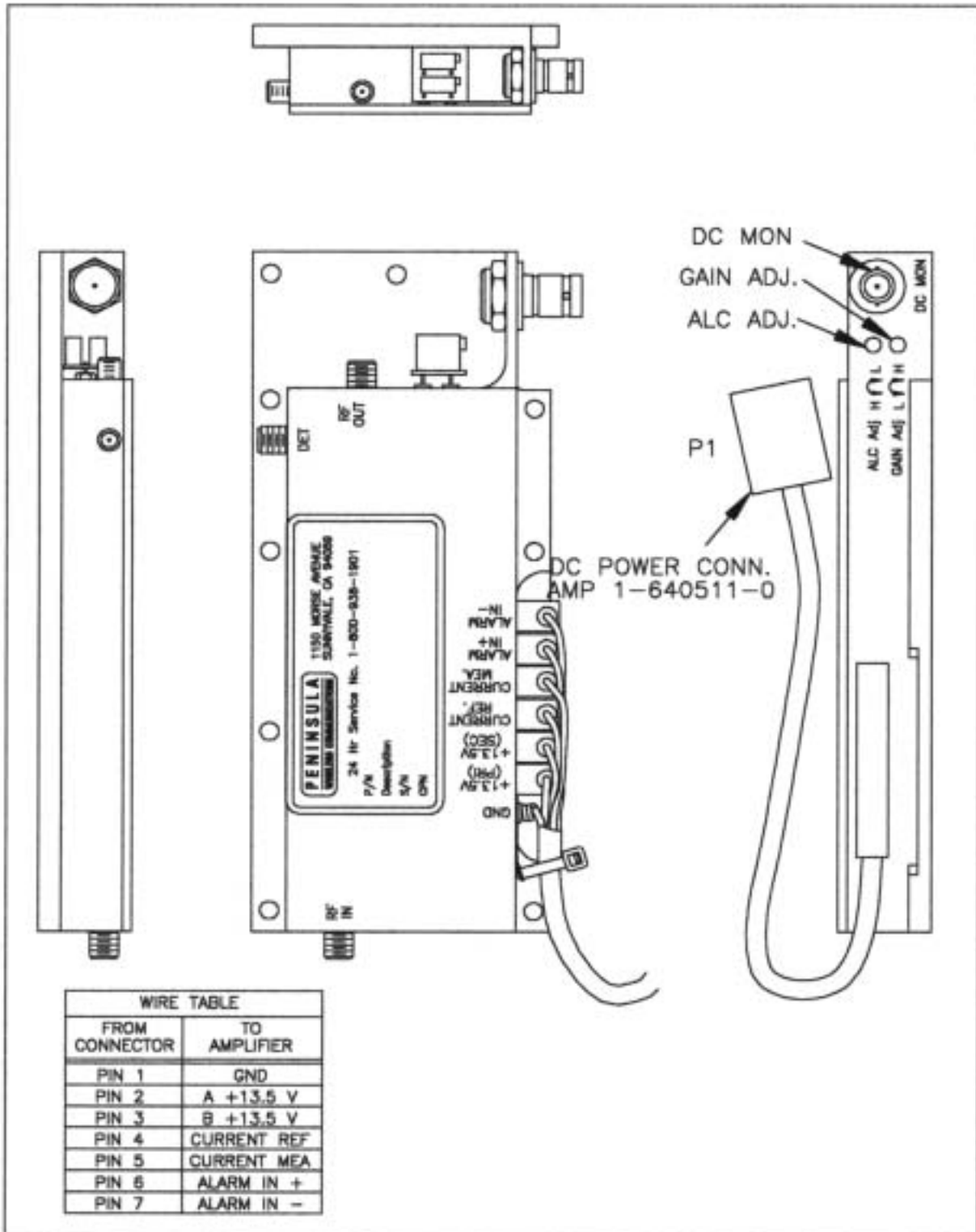

Figure 5. Amplifier

RF-15000 Repeater

well as easy amplifier replacement in the field. Necessary information for ordering spare or replacement amplifiers is provided in Part 5, Ordering.

Directional Couplers

- Directional couplers built into the amplifiers provide signal monitor points (see Figure 5) and allow in-service measurement of transmit output power. The monitor points are calibrated for calculating the actual RF output power at the antenna flange. When power is measured at the PWR MON port of the amplifier, the power meter reading obtained, plus the loss (in dB) marked at the amplifier monitor point, minus the branching loss (in dB) marked on the panel, equals actual transmit output power.

For example:

(1)	Power meter indication	=	+5.0dBm
(2)	Loss marked at monitor	=	18.2dB
(3)	Branching Loss	=	-2.2dB

	Output Power	=	+21.0dBm

AGC/ALC Adjustment

- There is a field-adjustable potentiometer on the amplifier (see Figure 5). The repeater output level and nominal gain is adjusted by the AGC/ALC potentiometer.

Linear Gain Adjustment

- Next to the AGC/ALC adjustment, there is a second field-adjustable potentiometer for linear gain adjustment to limit its maximum gain.

NOTE: Amplifiers are usually set to maximum linear gain by Repeater Technologies. Do not adjust this setting unless the path is extremely short, antenna isolation is marginal or otherwise recommended by Systems Engineer.

Power Supply

- The only active element in each frequency channel of the RF-15000 assembly is the amplifier, which operates from a +13.5 VDC source.
- Two DC supplies are brought into the repeater enclosure to

power the amplifiers in redundant-protecting mode. Current requirements for +13.5 VDC are 1.2 Amperes per duplex system and 2.4 Amperes per duplex frequency diversity system.

- The repeater assembly can be powered from solar panels or batteries, primary cells only, or from an AC/DC supply with standby battery (see Figure 6, Figure 7, and Figure 8).

- Storage batteries and solar cell panels are selected on the basis of the average insulation and temperature range at the site. The batteries are engineered to provide the required reserve capacity across the temperature range and during periods when the output from the solar panels is low or not available.

- Controllers are used with the solar panels to efficiently charge the batteries without overcharging. Repeater Technologies can determine the solar and battery capacity. Specify the site location when requesting assistance or placing an order.

- For areas in which commercial power is available, an AC power supply can be provided. Although one AC power supply provides ample current to power all amplifiers, Repeater Technologies recommends dual AC power supplies for greater reliability.

- The dual AC power supply system also contains two charge controllers and two sets of standby batteries to provide power during AC power failures. Each battery is float-charged while the power supply is on and has 100 amp-hours, or standard capacity. Additional batteries can be purchased if necessary for system requirements.

- For locations in which commercial power is not available and solar panel charging is impractical, primary cell batteries capable of powering an RF-15000 repeater in excess of a year are available. In such applications, the battery installation should be given an environmental shelter according to the manufacturer's recommendations.

3. ALARMS

- The RF-15000 Repeater can be provided with an optional alarm system to remotely monitor the repeater site. Typically monitored are:

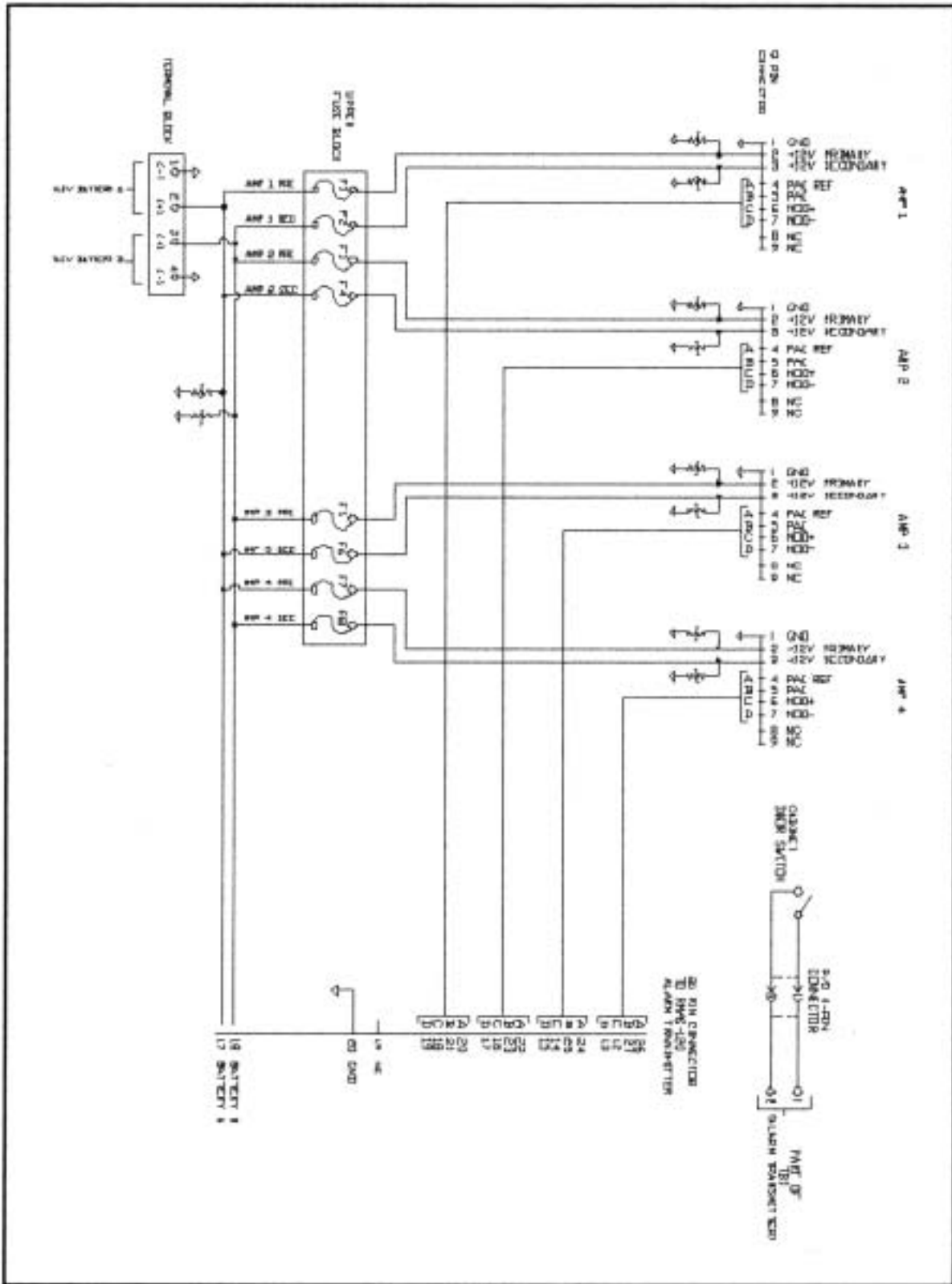

Figure 6. Repeater Wiring Diagram

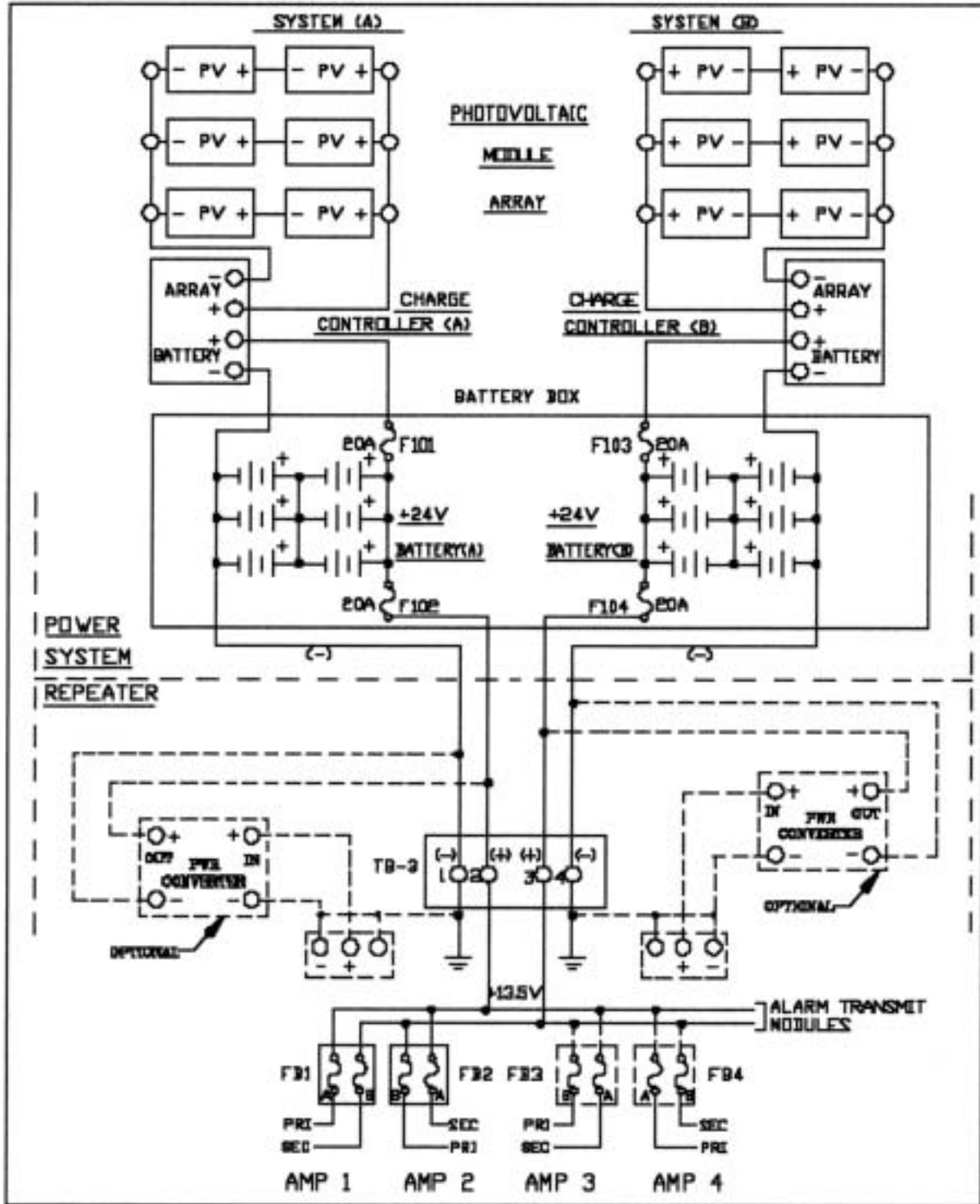

figure 1.1 Mechanical Layout (Duplex Figure 7. Power Connection Block Diagram)

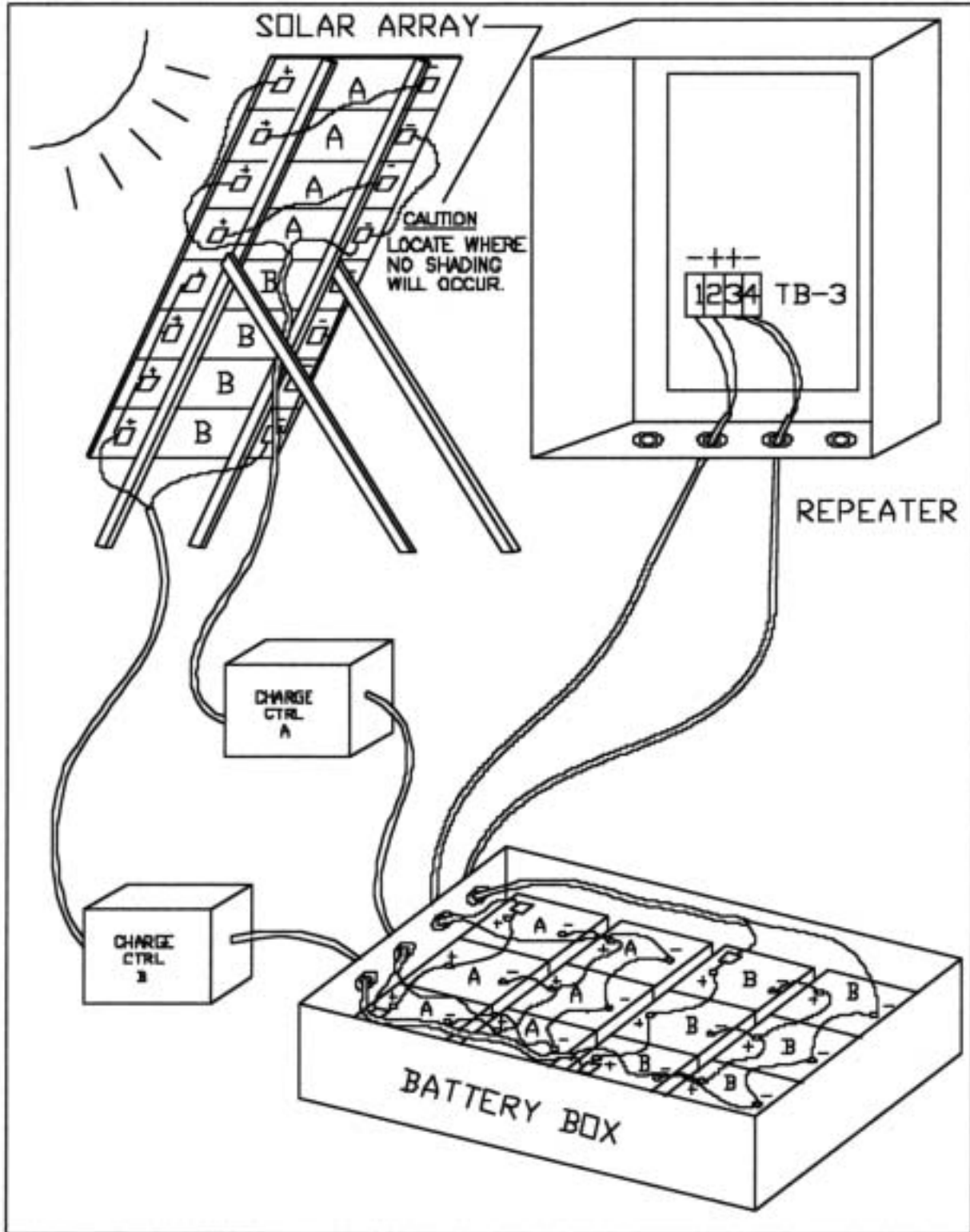

Figure 8. Repeater Power Wiring Illustration

RF-15000 Repeater

Standard Telemetry:

- a) A and B Battery Voltage
- b) Battery Temperature

Standard Trip Points:

- c) A and B Battery Major Alarm (2)
- d) East and West RF Output Low (2)
- e) Amplifier Alarm
- f) Cabinet Door Open
- g) Feedline pressure low
- h) 6 optional, user-affixed entry alarms (for doors, windows, and so on). Alarm may activate in either the closed or open state.

- The alarms are relayed back to the terminal through the use of a low-rate telemetry signal directly modulated on the RF in a non-interfering fashion. Alarms are displayed visually on the terminal receiver unit. Alarm receiver contact closure outputs are available for input to standard microwave supervisory systems.

4. ORDERING

- The RF-15000 RF Repeater Assembly is an RF-Through-Repeater designed for remote locations. The repeater assembly consists of an equipment mounting panel contained in an aluminum, weathertight cabinet.

- Orders should include:
 - a) The assembly name
 - b) Part number
 - c) Quantity required

- Indicate the shipping destination, billing address, and method of payment on the purchase order. An itemized order acknowledgment will be sent as soon as a purchase order is received, and an equipment list is included

with the shipment.

- Order the RF-15000 RF Repeater Assembly by specifying the system model number RF-15000-XX (see Table 3 on page 19). Attenuators are provided by specifying their part numbers (see Table 4).

- Because the necessary attenuator values are determined from the path calculations, complete transmission engineering before ordering.

- When doing the initial system layout of a radio hop that includes an RF-15000 RF Repeater Assembly, consider the following prior to ordering to ensure correct antenna connections — determine both terminal transmit-repeater receive frequencies (just F1 and F2, or F1 through F4) and the physical mounting of the RF-15000 Repeater on a tower (or crossarms) in relation to the mounting of antennas.

- The RF-15000 Repeater can be factory-tuned so that f1 RCV (A, LEFT) associates with the lower of the two frequencies and f2 RCV (B, RIGHT) with the higher; or vice versa. By comparing the factors listed above, correct antenna/waveguide feeding connections will result. The equipment order must specify all frequencies.

For example:

f1 RCV = 14755 MHz or f1 RX = 14945 MHz

f2 RCV = 14945 MHz f2 RX = 14755 MHz

- For spare replacement amplifier ordering, see Table 5.

- The alarm system is optional. For ordering information, see Table 6. For alarm spare parts ordering, see Table 7.

- One alarm transmit module can send information to terminals at one or both ends of the Repeater Link. Order receiver modules for one or two locations as needed.

Table 3
RF-15000 RF Repeater Ordering Information
Channel Bandwidth : 28 MHz

Standard Assembly	Part Number	Description	Frequencies (MHz)
RF-15000-01	900-0902-01	Duplex	F1, F2
RF-15000-02	900-0902-02	Duplex, Frequency Diversity	F1, F2, F3, F4

Table 4
Coaxial Attenuator

Stock Number	Attenuation	Part Number	Attenuation
149-0128-01	1.0dB	149-0128-11	11.0dB
149-0128-02	2.0dB	149-0128-12	12.0dB
149-0128-03	3.0dB	149-0128-13	13.0dB
149-0128-04	4.0dB	149-0128-14	14.0dB
149-0128-05	5.0dB	149-0128-15	15.0dB
149-0128-06	6.0dB	149-0128-16	16.0dB
149-0128-07	7.0dB	149-0128-17	17.0dB
149-0128-08	8.0dB	149-0128-18	18.0dB
149-0128-09	9.0dB	149-0128-19	19.0dB
149-0128-10	10.0dB	149-0128-20	20.0dB

Table 4
Spare/Replacement Amplifier Ordering

Description	Stock Number
Amplifier	090-0992-01
Sparing Kit	091-0005-01
Sparing Fuse	175-0028-01

Table 6
Alarms Ordering, RMAS-120

Standard Assembly Stock Number	Application on Repeater System
900-0782-01	Duplex (1+0)
900-0782-02	Duplex, Frequency Diversity (1+1)

Table 7
Alarm Spare Parts

Stock Number	Stock Number
090-0780-01	Receiver Unit
090-0781-01	Transmitter Unit, 1+0
090-0781-02	Transmitter Unit, 1+1
087-0444-01	Temperature Transducer
034-0004-01	Pressure Switch
034-0001-01	Door Switch

Contact the Repeater Technologies Sales Office for pricing and availability.

5. INSTALLATION

General

- When the RF-15000 equipment is received, inspect it carefully for damage. Claims for damage should be reported directly to the transportation company involved in accordance with their instructions. Any such claims should be made immediately after the discovery of damage.
- The RF-15000 assembly can be mounted on crossarms on a wood-pole structure, a steel tower, or on a wall. In extremely hot environments (such as desert), shading from direct sunshine may be required. Limit the length of all power leads and use a wire size adequate to minimize the voltage drop. The repeater assembly, battery boxes, solar panels, and antennas should all be mounted before any wiring is done. See Figure 9 for mounting hole dimensions of the repeater enclosures.
- Prior to cutting to length and connecting the waveguide feedlines, verify which repeater receive frequency is associated with each antenna port. The repeater receiving and transmitting frequencies are marked on the top of the repeater, near waveguide manifolds.
- The waveguide feedlines are terminated in the WR62 cover flange. The repeater is not designed for pressurization. Use external pressure windows at the WR62 cover flange if the feeder lines are to be pressurized.

Power Wiring

- Remove all fuses from power supply board on the right-hand side of the repeater and remove the fuses (F101, F102, F103 and F104) from the holders in the battery boxes, if storage batteries are used.

NOTE: Do not replace any fuses until after electrical tests are complete.

- The power leads can be brought into the repeater housing through the 1/2 inch (13 mm) non-metallic conduit (NMT) fittings provided. Use paired 10-gauge (2.50 mm) wire from both batteries to the repeater terminal blocks and from the solar panels to the charge controller terminal block.
- Connect the negative leads from the negative battery terminals to 1 and 4 of terminal block TB-3 (see Figure 1.7). Then connect the positive leads from the positive battery terminals to 2 and 3 of terminal block TB-3.
- If a single AC/DC converter is used, jumpers must be installed between terminals 2 and 3 on the lower side of TB-3 (see Figures 1.1 and 1.2). Note that the equipment uses a negative ground.

NOTE: TB-2 and TB-3 are reserved for the case when the main power supply is other than 12VDC. Any power converter must be used according to Figure 1.7. See Section: Application of Power.

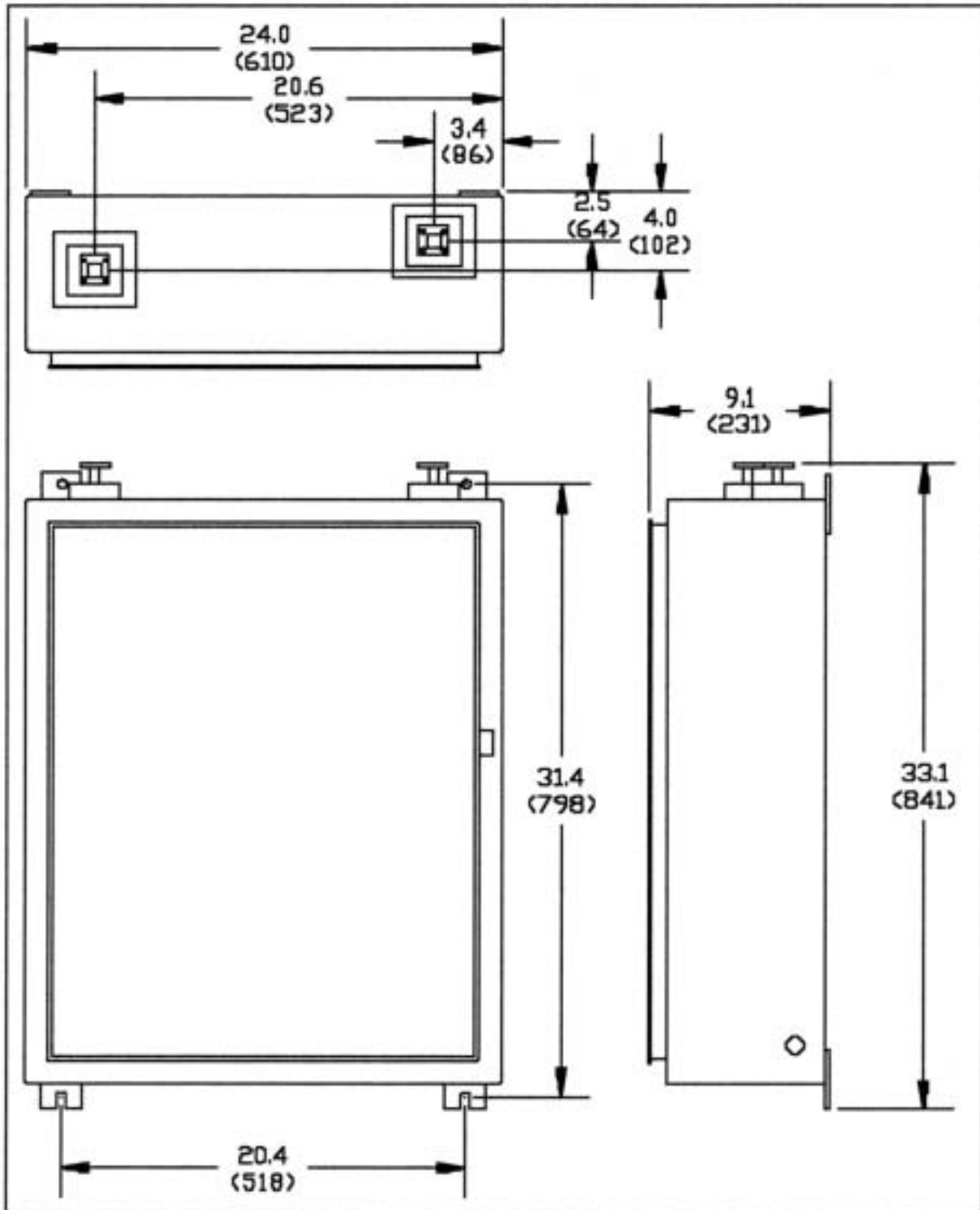

Figure 9. Cabinet Mounting Dimensions, RF-15000, -01 and -02

DC Power

- The repeater normally is powered from redundant dual DC power systems—designated systems A and B.
- The A battery is wired to power the A side of the equipment. Similarly, the B battery is wired to power the B side of the equipment.
- Standby power switchover is accomplished within each amplifier. Each amplifier has a primary and secondary +13.5 VDC input. If the primary DC power system fails, operation immediately continues on the secondary DC power system (see Figure 1.7).

NOTE: To complete installation, proceed to Chapter 5. Tests, and follow all procedures.

6. TESTS

General

- Few adjustments are required on the RF-15000 Repeater. Once the application of power, AGC/ALC adjustment, and proper antenna orientation are performed, the equipment is ready to be placed in service. Use a portable or mobile radio to establish a talk path between the RF-15000 Repeater site and the terminals to aid in completing the tests and in verifying normal (calculated) system operation.

Test Equipment

- The description of test equipment includes the manufacturer's type/model numbers that are available as of the publication date of this manual (see Table 4.A). Because certain models of test equipment can be discontinued or superseded by the manufacturer without notice, use current catalogs when ordering equipment.
- The manufacturers of test equipment listed are for reference only and are not intended to show a preference for any

one manufacturer. Equivalent test equipment can be used unless otherwise noted. All test equipment should be properly maintained, calibrated, and operated according to the manufacturer's instructions.

Application of Power

- Remove all fuses from the holders in the battery boxes and fuse blocks on the repeater if they are in place.
- Measure the voltage across Charge Controller input terminals (+) and (-) if solar panels and storage batteries are used.
- Confirm the proper polarity. The voltage reading should be between 12 and 17 Vdc. If the polarity is incorrect or there is no voltage, check and correct the wiring to the solar cell panels. If the voltage is low, check to be sure the surfaces of the solar panels are not obscured from sunlight by shadows.
- Re-install battery box output fuses F102 and F104.
- On the repeater, measure the voltage across terminals 1(-) and 2(+); and across terminals 3(+) and 4(-) of TB-3. Confirm the proper polarity. The voltage reading should be +12.5 to +13.5 Vdc for storage batteries or +13 to +15 Vdc for an AC/DC converter power supply. If the polarity is incorrect or there is no voltage, check and correct the wiring of the batteries or AC/DC converter power supply by following these procedures:
 - Remove battery box output fuses, F102 and F104.
 - Re-install battery box input fuses, F101 and F103.
 - Re-install all fuses of fuse blocks (FB1, FB2, and so on) on the repeater.
- Set the DVM (digital voltmeter) to read in a range of 5A or greater and put its test leads in series between positive lead from battery system A and terminal 1 (+) of TB-3 on the repeater (see Figure 7 on page 15). Alternatively, use leads on fuse holders of F102 and F104. Once the current stabilizes (this takes about 30 seconds), it should be within the limits shown in Table 4.B.

**Table 8
Recommended Test Equipment**

Item	Manufacturer and Type Number	Use	Quantity
DVM	Fluke 75 or equivalent	Measure 18 to 35 Vdc and current from 10mA to 20A	1
RF Power Meter	Hewlett-Packard 435B equipped with 8481A or equivalent	Antenna orientation and output power measurements (-10 to +25 dBm)	1
Spectrum Analyzer	Hewlett-Packard 8563A or equivalent	Antenna orientation	1
Attenuator	Microlab/FXR AJ-500F, 30 dB or equivalent	Antenna orientation and power alarm set (RMAS-100)	1

**Table 9
Current Requirement
with One Power Supply On**

RF-15000-01	1.2 A Max.
RF-15000-02	2.4 A Max.

• Repeat the above procedure to measure current from battery system B and terminal 1 (+24) of TB-2 on the repeater. Again, See Table 4.B for appropriate current limits.

NOTE: During installation, routine maintenance, and trouble location procedures, log all voltage and current readings in Table 5.A for reference.

• Re-install battery system B output fuse (F104). Then make a current measurement from Battery System A to terminal 1 (+12) of TB-3 again. Be sure the reading falls within limits defined in Table 4.C. Log reading in Table 5.A. Re-install battery system A output fuse (F102).

**Table 10
Current Requirement on One Power
Supply with Both Power Supplies On**

RF-15000-01	0.6 A Max.
RF-15000-02	1.2 A Max.

Antenna Isolation Measurement

• In order to prevent oscillation or severe passband distortion, the antenna must have a minimum port-to-port isolation. See Appendix A for detailed information.

• Measure the isolation by sending a signal into one of the antenna feeders and measuring the level of that signal at the other antenna feeder. The signal power level difference in dB is the isolation of two antennas.

NOTE: The motion of objects near the antenna can change the isolation. If possible, tests should be made with any

expected objects present to ensure that isolation does not drop below the acceptable minimum.

- Repeat the test at frequencies across the designated bandwidth, making sure the minimum isolation is met at all frequencies. If minimum isolation is not met, try repositioning the antenna or adding intervening shielding until readings are acceptable.

Antenna Orientation, AGC/ALC set and Output Measurement

- Before antenna orientation begins, the amplifiers must be operating at full gain mode (out of AGC/ALC range). The setting of the AGC/ALC in conjunction with a high input level (an input level greater than the difference between the desired output power level in dB and the maximum linear gain in dB [that is, high input level > output level – maximum linear gain]) can cause the normal action of the AGC/ALC circuit to mask changes in power due to azimuth and elevation sweeping of the antennas.

- The output power of an amplifier increases in level as the input level is increased to the point where the AGC/ALC has been set (that is, +18 dBm). Further increases in input level are absorbed in the AGC/ALC circuit. Use the amplifier power monitor point as a signal strength indicator.

- The input level can be reduced temporarily by inserting a fixed or variable attenuator pad ahead of the amplifier. The attenuation required ranges from 0 to 30 dB, depending on desired power and input signal level. Remove the input semi-rigid coax cable and place the attenuator in series with the coax, or use flexible coax as required for fit. Reduce the input level until the output power is below the desired power level. If the power rises to the desired power level during antenna orientation, reduce the input level again and then continue with antenna orientation.

- For example, with a repeater of 51 dB maximum gain and output at +19 dBm, the testing input signal level must be below -32 dBm.

NOTE: Alternatively, the amplifier's maximum gain can be reduced by using the GAIN Adj potentiometer (see Figure 1.5 for location) so that the system is out of AGC/ALC for antenna alignment. Be sure to return potentiometers to their normal positions once antennas are aligned—usually at the maximum linear position.

To Perform Antenna Orientation

- Connect the power meter or spectrum analyzer to the f1 amplifier, A1, RF PWR MON port.
- With a signal transmitted from the A terminal, position antenna A for a maximum power reading on the meter or analyzer.
- After antenna A is aligned, remove any temporarily installed input attenuators.
- Reset the power level with the AGC/ALC adjustment if needed. The AGC/ALC adjustment is located near the output end of each amplifier; See Figure 1.5.
- Use a screw driver to adjust the AGC/ALC potentiometer CW to reduce the power setting or CCW to increase the AGC/ALC set point.

NOTE: Log the power reading to meet FCC requirements.

- Remove the meter from the f1 Amplifier PWR MON to the f2 Amplifier PWR MON.
- With a signal transmitted from the B terminal, position the antenna B for a maximum power reading on the meter or analyzer.
- After antenna B is aligned, remove any temporarily installed input attenuators.
- Set the power level with the AGC/ALC adjustment if needed.

NOTE: Log the power reading to meet FCC requirements.

- Measure and log the power at any additional amplifier directional couplers so equipped (f3, f4, and so on).
- Remove the meter.
- After the antenna orientation has been completed at both terminals and the Repeater, AGC readings should be taken at the end terminals and logged for reference.
- If required in the field, the RX/TX pads should be installed

RF-15000 Repeater

at the RF input or output of amplifiers. To install it, turn off the DC power supply first. Disconnect the input/output semi-rigid cable from the amplifier. Connect the SMA male end of the pad to the amplifier SMA female input/output; and then connect input/output cable to the other end of the pad. Check all coaxial connections for tightness (8 in-lbs.). Set output power level by adjusting AGC/ALC.

7. MAINTENANCE

Routine Maintenance

- Unless unique conditions require more frequent maintenance, routine maintenance should be performed annually. Clean the surfaces of the solar cell panels with isopropyl alcohol or a mild detergent solution. Do not use alcohol compounds containing acetone. Check and clean the wiring connections to the solar charge controllers and the battery connectors as necessary. Measure the current of the repeater system. The current reading should be within the appropriate limits. Also measure the power level at PWR MON of each amplifier with a power meter. Log current and power readings in Table 5.A.

Administration Requirements

- The US-FCC or other local telecommunications administrations may require measurement of the output power of the repeater at installation or when any changes are made that cause the output power to change. Use the power meter to measure the output power and ensure it is within the specified range.

Trouble Location

- Soft failure of one amplifier causes a reduction of approximately 6 dB in the received signal level at the terminal in the direction of transmission—indicated on the AGC meter on the terminal equipment. Amplifier AGC/ALC can correct for this drop. The failure of one amplifier most likely is caused by a failure of DC power to the amplifier. Using the DVM, check for the presence of DC voltage at the amplifier power feed-through connections. Another way to check is to insert DVM probes to pins #1 and #2 (or #3) from the back side of amplifier wire harness (see Figure 1.5).

- If the received signal at the terminals is low but does not indicate a complete failure on one amplifier, the most likely cause is low voltage from the batteries. Low voltage is caused by:
 - A possible DC-DC converter failure.
 - Battery failure.
 - A failure of the charging system.

- Check the batteries and all power lead connections. If solar panels are used, be sure they are not obstructed from sunlight and that the surfaces are clean. If an AC power supply is used, low voltage probably is the result of a power failure, the duration of which exceeded the reserve power limits of the standby battery. Check the standby battery in accordance with the instructions given by the manufacturer of the power supply.

Amplifier Replacement, Out of Service

- When an amplifier must be replaced in an out-of-service condition:

- a) Unplug amplifier's power connector.
- b) Disconnect input and output SMA cables.
- c) Disconnect BNC cable from DC monitor point.
- d) Remove mounting hardware.
- e) Remove amplifier.

- To install the replacement amplifier:

- a) Mount the amplifier on the panel securing with mounting hardware.
- b) Connect the BNC cable to DC monitor point.
- c) Connect input and output SMA cables.
- d) Check all coax connections for tightness (8in/lbs)
- e) Plug-in the amplifier's power connector.
- f) Verify operation by measuring power at SMA power monitor.
- g) Set output power by adjusting AGC/ALC.

Amplifier Replacement, In Service

(For Duplex and One-Way Options Only)

- When an amplifier must be replaced while the repeater is in service (such as the occurrence of soft failure):

- a) Mount and orient a temporary spare amplifier in the same input/output direction as the amplifier to be replaced.
- b) Remove the SMA terminations from the coaxial

circulators in series with the amplifier to be replaced (see Figure 1.1).

- c) Connect the flexible coaxial cables or semi-rigid coaxial cables (part of the sparing kit) from the input (RX) coax circulator open port to the temporary spare amplifier's input SMA. Likewise, connect the output (TX) coax circulator open port to the temporary spare amplifier's output SMA connector.
 - d) Connect the DC leads from the temporary spare amplifier using the power adapter in the sparing kit to the "A" side of TB-3 if replacing amplifier A1, or "B" side of TB-3 if replacing amplifier A2.
 - e) Disconnect the input coaxial circulator from the amplifier to be replaced. The signal is now carried in the temporary spare amplifier, but may be 20 dB down until step (7) is carried out.
 - f) Unplug the power connector of the amplifier to be replaced.
 - g) Disconnect the output coaxial circulator from the amplifier to be replaced.
 - h) Re-set the output power of the temporary spare amplifier by adjusting its AGC/ALC.
 - i) Move the BNC cable from the DC monitor point of the replaced amplifier to the temporary spare amplifier.
 - j) Unscrew mounting hardware and remove the defective amplifier.
- To install a replacement amplifier in service:
 - a) Mount the amplifier on the panel securing with mounting screws.
 - b) Connect BNC cable to DC monitor point.
 - c) Connect the output coaxial circulator to the replacement amplifier's output. Signal level will drop 20 dB.

- d) Plug in the amplifier's power connector.
- e) Connect the input coaxial circulator to the replacement amplifier's input. Signal level should be close to normal. Set power by adjusting AGC/ALC.
- f) Remove the power connections from the temporary spare amplifier.
- g) Disconnect the flexible or semi-rigid coax cables from the coax circulators and from the temporary spare amplifier.
- h) Replace the SMA terminations on the coax circulators. Check the output power of the amplifier. Re-set its power by adjusting AGC/ALC if needed.
- i) Remove the temporary spare amplifier.

CAUTION

Due to unpredictable reflections within the RF-15000, there may be some degradation from normal when operating with a temporary spare amplifier, particularly in high-capacity digital and analog systems. Be sure the AGC/ALC is set for the correct power level in your system

Return Procedure

- Once it is determined that a unit is faulty, contact the Peninsula Engineering Repair Department at: 1-925-901-0103. A representative will issue a Return Authorization Number (RMA) and shipping instructions.

- Ship the units in containers similar to those (if not the same) in which the units were originally delivered in order to minimize the potential for shipping damage. Insure that the packing material adequately isolates the units from undue contact with the shipping container.

**TABLE 8.1
PENINSULA ENGINEERING
RF-11000 MAINTENANCE RECORD**

Date				
Solar Panel, System A Voltage :				
Solar Panel, System B Voltage :				
Battery, System A Voltage : Temperature :				
Battery, System B Voltage : Temperature :				
Current Drawn From Battery A Only				
Current Drawn From Battery B Only				
Current Drawn From Battery A While Battery B is Connected				
Amplifier, A1 F1 Power Monitor :				
Amplifier, A2 F2 Power Monitor :				
Amplifier, A3 F3 Power Monitor :				
Amplifier, A4 F4 Power Monitor :				

APPENDIX A

Antenna System

The antenna system is vital to the success of any RF Repeater. It was only when high-performance microwave antennas became available that high-capacity RF Repeaters became practical. Antennas must have high gain (25-50 dB), clean pattern, low sidelobes and good Front-to-Back ratio. The sidelobes and the Front-to-Back ratio control much of the echo that results from antenna to antenna coupling. Foreground obstructions also produce a site-specific echo component.

The objective for permissible echo varies with the type of transmission and its bandwidth. High-capacity analog radios require 50-55 dB C/I, C/E, and low-capacity analog and digital radios require 24-40 dB C/I, C/E. The actual amount of echo permitted must be calculated based on the radio manufacturer's specifications and end-system design requirements. See Table A.1 for the required RF repeater C/I, C/E with different types of radios.

For example, a 4 PSK digital system requires 24 dB C/I, C/E at the repeater. The 15 GHz RF Repeater gain is 55 dB.

Antenna-to-antenna decoupling required is $24 + 55 = 79$ dB. This can be obtained from two 46 dB gain standard 6-foot antennas with 55 dB Front-to-Back ratio (F/B). XPD (Cross Polarization) of the antenna is recommended. An antenna XPD of 20 dB is easily achieved. Antenna separation loss of 48 dB is assumed by taking 75% of free space loss between the feeds of the two antennas. The decoupling now is as follows:

+55	dB	F/B of Antenna #1 (standard)
-46	dB	Gain of Antenna #1 (6 foot)
+55	dB	F/B of Antenna #2 (standard)
-46	dB	Gain of Antenna #2 (6 foot)
+20	dB	Antenna XPD
+41	dB	Antenna separation loss (3 feet)
<hr/>		
79	dB	Total decoupling loss
-55	dB	Repeater Gain
<hr/>		
24	dB	C/I, C/E

In this situation, two standard antennas are adequate. If the repeater antennas could not be cross polarized, one or even two high-performance antennas should be used.

Table A-1
C/I Requirements For Digital Radios

For -1 dB system gain at 10^{-6} BER or $BER < 10^{-12}$ at normal RSL, use following table:

MODULATION TYPE	MINIMUM C/I
4 PSK QPSK, OQPSK	24
8 PSK	28
16 QAM	33
64 QAM	40
MSK/FSK	30
9 QPRS/QPR 3	31
25 QPRS/QPR 5	32
49 QPRS/QPR 7	33
81 QPRS/QPR 9	35